



High-Performance Turbochargers Catalog

 **BorgWarner**

About BorgWarner Turbo Systems

BorgWarner turbochargers provide customers worldwide with a comprehensive range of 3K and Schwitzer replacement turbochargers and spare parts.

For over 100 years, BorgWarner has demonstrated its commitment to advancing the automotive industry and motorsports through a continuous stream of technological advances. In particular, these advancements flourished in the late 1990s when BorgWarner embarked on a series of critical initiatives that immediately turned them into a pacesetter within the turbo technology industry.

In October of 1998, BorgWarner purchased 100% of the net assets of German turbocharger and turbo machinery manufacturer, AG Kühnle, Kopp & Kausch, renaming it 3K-Warner Turbosystems. In March of the following year, BorgWarner acquired Kuhlman Corporation as a means to gain access to Schwitzer, Inc., a leading manufacturer of turbochargers for commercial transportation and industrial equipment.

With the integration of 3K-Warner Turbosystems and Schwitzer, BorgWarner continues to set new technological standards in the field of engine boosting.

Fast forward to the new millennium where BorgWarner Turbo Systems has become a well positioned player in the engine boosting arena, with development centers, production sites and sales offices throughout the world.

In keeping with our maxim “Local Power—Global Strength” we use all of the resources and talents available within our worldwide organization to exceed the expectations of our customers. To ensure that our sites work efficiently around the world, we have standardized vital processes and best practice methods, without compromising location-specific flexibility and autonomy. Our goal is to continually offer you solutions that are perfectly tailored to meet the specific requirements of you and your market.



Louis Schwitzer
Automotive Hall of Fame

C O N T E N T S

VOLUME IX

2	Technology & Innovation	42	S200SX-E
6	Commitment to Performance	43	S300SX3
7	History of the Borg-Warner Trophy™	45	S300GX
8	BorgWarner Boosted	46	S300SX-E (NEW 72mm)
16	Match-Bot Instructional	48	S400SX
18	EFR	50	S400SX-E
20	EFR Rotor Groups	52	S400SX3
22	EFR 6258	53	S400SX4
23	EFR 6758	55	S500SX
24	EFR 7163	56	S500SX Super-Core
25	EFR 7064	57	S500SX-E
26	EFR 7670	58	S410SX
27	EFR 8374	59	BV50 (Porsche 997 upgrade)
28	EFR 8474 (NEW)	60	TSG-1, Turbo Speed Gauge
29	EFR 9174	61	Optional Speed Sensor, Boost Port and V-Band Connections Instructions
30	EFR 9274 (NEW)	62	BorgWarner Turbos for Upgraded Passenger Car Engines
31	EFR 9180	64	K03-2080 (Mini upgrade)
32	EFR 9280 (NEW)	65	K04-2075
33	The Right Turbo For You	67	K04-2283
34	Turbo Frame Dimensions	68	K16-2480
36	Ancillary Parts	69	WARRANTY STATEMENT
38	AIRWERKS		
40	S1BG		
41	S200SX		

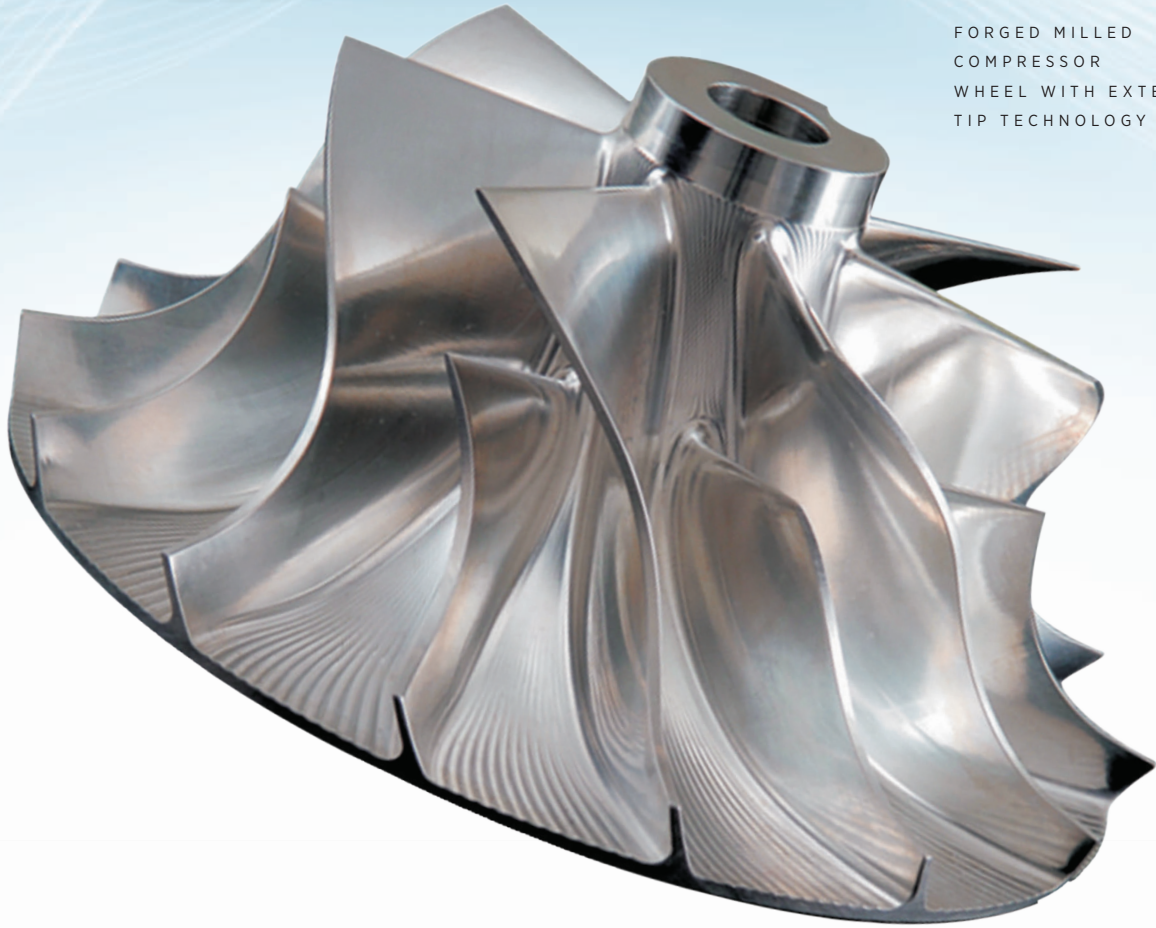

FORGED MILLED
COMPRESSOR
WHEEL WITH EXTENDED
TIP TECHNOLOGY

TECHNOLOGY



TWIN SCROLL
TURBOCHARGER TECHNOLOGY



EFR TURBOCHARGER
TECHNOLOGY



AIRWERKS TURBOCHARGER
TECHNOLOGY

Innovation, speed, flexibility, quality and an acute customer focus are the benchmarks by which our customers measure us.

As a result, we not only are constantly developing new technologies internally, but are also seeking ways to continually improve the external relationships with our customers. We value the spirit of cooperation and strive to always enhance the processes regarding product development, manufacturing and quality assurance.

The speed in which we share product data with our customers is also becoming an increasingly important factor in setting up optimum processes. From the very start of development, we involve people from the design, production, purchasing and quality assurance areas.

+ innovation

By collaborating at the beginning of the process we are able to save both time and money, ensuring that the turbocharging systems we supply meet proven serial production quality, reliability and performance standards at the onset of production.

The latest generations of compressor and turbine stages assure optimum thermodynamic results. With the further development of materials and processing methods – such as forged milled compressor wheels – we not only optimize performance, but also enhance durability and reliability of our turbocharging systems.

Turbocharger assembly



Forged-milled compressor wheel production



TECHNOLOGY + innovation

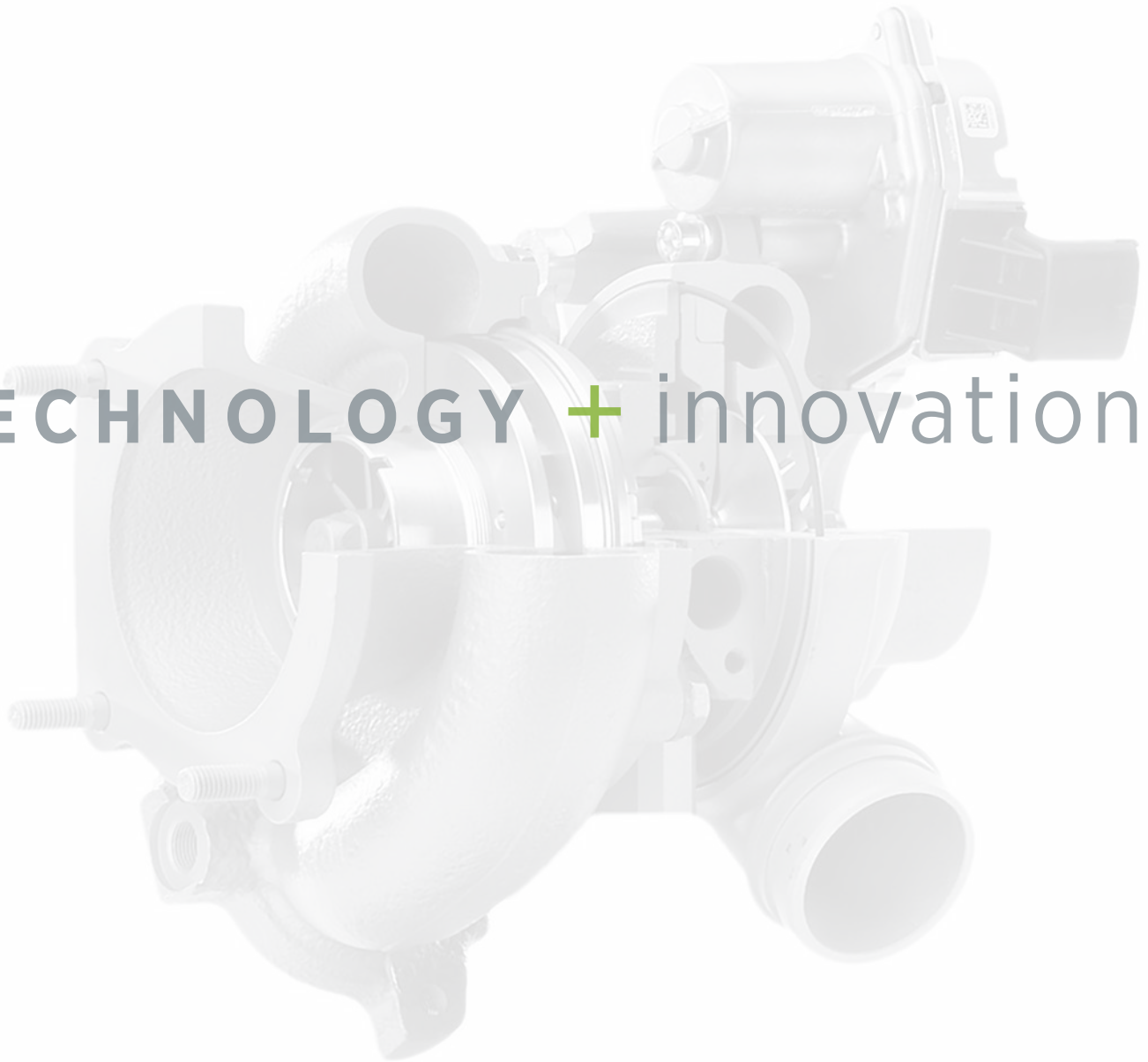

Real world testing
Photo courtesy of: Fredric Aasbo Racing



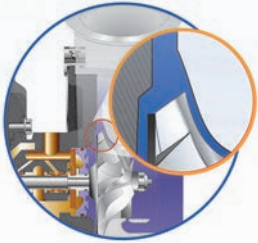

Compressor wheel with extended tip technology

Extended Tip Technology

Select BorgWarner turbochargers employ BorgWarner “S” generation compressor wheels that incorporate extended tip technology. This compressor wheel design feature promotes greater airflow using a low inertia wheel that performs like a wheel of greater size and mass. Extended tip technology enables the user to have faster spool-up at lower engine speeds while providing the boost for the powerful top-end performance that most turbocharger enthusiasts have come to desire. Turbochargers have to meet different requirements with regard to map height, map width, efficiency characteristics, moment of inertia of the rotor and conditions of use. New compressor and turbine types are continually being developed for various engine applications with compressor wheels having an increased influence on

the engine’s operational characteristics. These wheels are designed using computer programs that develop a three-dimensional calculation of the airflow and pressure.



The twin scroll turbocharger generates higher boost pressure at low revs

Twin scroll technology produces results similar to twin-turbo applications, but in a smaller package with lower weight and cost. In turbochargers of this type, the channels between the exhaust manifold and turbocharger of the first and fourth as well as the second and third cylinders are separated from each other. The exhaust gas streams are directed into so-called scrolls (spirals) and then reunited again directly at the turbine wheel. Separating the streams in this way offers improved performance.

With this type of charging, spontaneous boost pressure can be built up 1000 RPMs earlier, which significantly improves response in the low rev band. The engineers at BorgWarner have also mastered the problem of high exhaust gas temperature in gasoline engine turbocharging despite the genuine challenge presented by such a compact turbine casing with two scrolls. One approach employed by the engineers here was to develop a new downsizing method of casting turbine housings to improve their temperature resistance and guarantee the quality needed. The benefits of the twin scroll turbocharging technology and other market-leading technologies by BorgWarner Turbo Systems offer passenger vehicles, dynamic performance, low fuel consumption and lower CO₂ emissions.

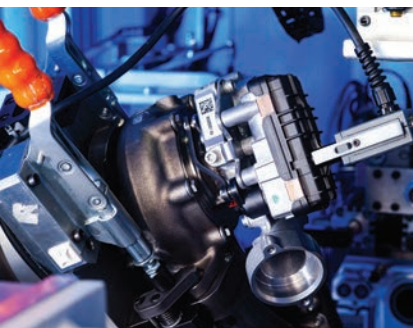

Turbo functional testing



MERCEDES SILVER ARROW C11

Mercedes Silver Arrow C11, World Sportscar Champion.
5.0 liter V8 twin 3K turbo engine

commitment to PERFORMANCE

AirWerks is an independent aftermarket program from BorgWarner Turbo Systems. This venture is focused on creating exceptionally high engine performance through forced induction technology. Why do the world's most prominent auto manufacturers select products from BorgWarner Turbo Systems? Simply put, we are the

world leader in turbos for high speed, high temperature gasoline engines. The BorgWarner Turbo Systems performance line features an assortment of carefully chosen K and S series turbochargers and the EFR series to meet a wide array of high-performance engine requirements. These turbos will be steadily

improved based on the latest findings in aerodynamic and materials technology.

INNOVATION, A FRUIT OF COMPETITION Racing has long been known as a fertile research and development arena and proving ground for new technology. BorgWarner takes full advantage of its rich racing heritage using some

of the same materials and aerodynamic techniques that produced boost for winning cars, elevating and incorporating it into the hardware available through BorgWarner Turbo Systems. Partnerships fostered at the track can create alignment and uncommon results, in the marketplace.



AUDI 90 (QUATTRO) GTO

Audi 90 (quattro) GTO was one of the most technologically advanced four-door race cars to ever hit the tracks. The 1988 Trans Am Manufacturer's champion was banned from the 1989 season due to its dominance. Boost was provided by a single BorgWarner K-series turbocharger.



The Borg-Warner Trophy™

The Borg-Warner Trophy, is synonymous with high performance, speed and leading-edge automotive technology. In 1936, Eddie Rickenbacker, of the Indianapolis Speedway, unveiled the Borg-Warner Trophy and officially announced it as the prize for the champion of the Indy 500.

Commissioned by The BorgWarner Automotive Company in 1935, the trophy is made of sterling silver and stands over 5 feet tall, weighing nearly 155 pounds. The Trophy features a checkerboard pattern that bears the likeness of every winning driver since 1911 along with the date of their victory, and their average speed. Today, the trophy is housed in the Hall of Fame Museum at the Indianapolis Motor Speedway®. Each May, the Borg-Warner Trophy is featured at a number of Indianapolis 500 events. These include the drivers' meeting at the track and the 500 Festival Parade in downtown Indianapolis, both on the day before the race. Immediately after each race, the trophy is hoisted into Victory Circle along with the winning car and driver for photographs. A tradition dating back to 1936 when after winning his third race, Louis Meyer received the first trophy and promptly said, "winning the Borg-Warner Trophy is like winning an Olympic medal."

The Borg-Warner Trophy™ is a registered trademark of BorgWarner Inc.



A L E G A C Y O F



Twin EFR-7163 turbochargers used to boost the Verizon IndyCar® Series.



Mixed Flow Turbine Technology currently used on the EFR-7163 turbocharger.

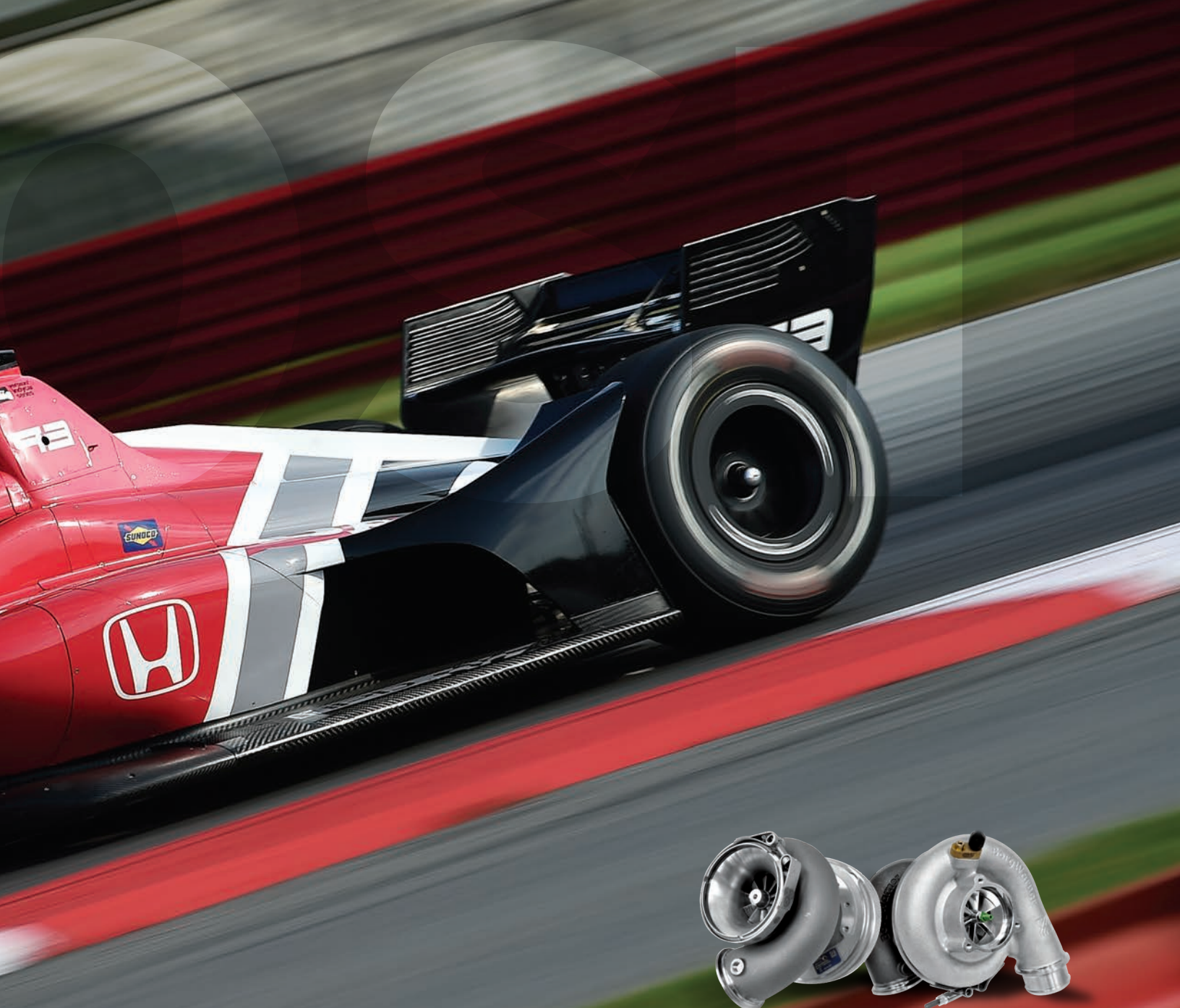

BorgWarner is proud of its long history of pushing the limits of technology.

From the first appearance of forced induction motor vehicles at the Indianapolis Motor Speedway® in 1952 to the Mulsanne Straight of Le Mans and the winding roads of Nürburgring,

BorgWarner turbochargers have made their mark.

Our decades of participation at the highest level in professional motorsports has provided tremendous experience and allowed us to further sharpen our precise engineering skills. And that legacy of excellence is embedded in every genuine

BorgWarner turbocharger that we produce today.

In 2012, the IZOD IndyCar Series (now known as the Verizon IndyCar Series®) saw the return of the turbocharged engine with BorgWarner leading the way with its pace setting engine boosting technology.

BO



Team: Plewniak Racing

Driver: Nick Plewniak

Vehicle: 1930 Plymouth sedan

Racing Venue: Hot Rod Drag Week

Current Turbos of choice:

Twin BorgWarner S400SX-E 80mm



Team: Four Ring Performance

Driver: Jeff Gerner

Vehicle: 1992 Audi S4

Racing Venue: World Land Speed Racing, Bonneville

Current Turbo of choice:

S400SX 82mm



Team: Aaron Parker Motorsports

Driver: Aaron Parker

Vehicle: 1993, Mazda Fd3s Rx7

Racing Venue: Formula Drift Pro-Am, Just Drift - Top Drift, Southwest Drift, Golden Gate Drift

Current Turbo of choice:

EFR-9174

BOOSTED



Team: PZ Tuning
Driver: Will Au-Yeung
Vehicle: 2012 Honda Civic Si
Racing Venue: World Time Attack Challenge

Current Turbo of choice:
EFR-9180



Team: GReddy Toyota Racing
Driver: Ken Gushi
Vehicle: Toyota FR-S
Racing Venue: Formula Drift
Current Turbo of choice:
EFR-9180



Team: Jager Racing
Driver: Mark Jager
Vehicle: 2006 Subaru Sti
Racing Venue: Global Time Attack, Redline Time Attack
Current Turbo of choice:
EFR-9174





Team: Papadakis Racing/
Need for Speed

Driver: Fredric Aasbo

Vehicle: 2017 Corolla IM
RWD conversion

Racing Venue: Formula Drift

Current Turbo of choice:
EFR-9174

Builder: Phil Sohn

Vehicle: Mazda RX-7

Current Turbo of choice:
EFR-8374



Team: Fredric Aasbo Racing

Driver: Fredric Aasbo

Vehicle: Icom Toyota 86-X

Racing Venue: Gatebil festivals,
European drift competitions

Current Turbo of choice:
EFR-9180



“Hands down
the best turbo
I’ve ever run.”

JESSE HOWARD

Driver: Jesse Howard

Vehicle: Polaris RMK Snowmobile

Racing Venue: “Anywhere there is snow and another sled.”

Current Turbo of choice:

EFR-6258

Team: Penske

Vehicles: No. 6 & No. 7 Acura ARX-05 DPi

Racing Series: IMSA WeatherTech
SportsCar Championship

Current Turbo of choice:
**Twin EFR 6258, wastegates
controlled by BorgWarner
Electric Actuators**



Team: Industrial Injection Race Team

Driver: Jared Delekta

Vehicle: 2001 Chevy 2500 HD

Racing Venue: NHRDA, ODSS

Current Turbo of choice:
**(2) S400SX-E 88mm and
(1) S500SX-E 94mm**



Team: DNA Racing

Driver: Alexa Taylor

Vehicle: 1968 Camaro

Racing Venue: Drag Week 1320

Current Turbo of choice:
Twin S300SXs

Team: RAD Industries

Driver: Rad Dan Burkett

Vehicle: 2JZ Toyota Supra

Racing Series: Formula Drift Pro1

Current Turbo of choice: EFR-9174





Driver: Michael Essa

Vehicle: 2005 BMW M3

Racing Venue: Formula Drift

Current Turbo of choice:
EFR 0



Team: Worhouse

Drivers: James Deane /Piotr Wiecek

Vehicles: Nissan S15

Racing Venue: Formula Drift

Current Turbo of choice:
Twin EFR-9180

match-bot

INSTRUCTIONAL

The team at BorgWarner has developed Match-Bot, an interactive turbo matching program that is internet based. The program begins by entering the engine input data. For each piece of input data, helpful pop-up's are provided. These useful tips guide the user through entering appropriate engine targets by means of giving optimal example ranges. Parameters such as BSFC, VE, and exhaust gas temperature are often difficult for the user to estimate, but helpful suggestions are offered each step of the way.

Solutions for single or twin turbo configurations



Corrects turbo speed and capability for operating altitude

Each required input has suggested ranges that help users estimate values for categories such as Volumetric Efficiency and Brake Specific Fuel Consumption

CALCULATED OUTPUTS

		#1	#2	#3	#4	#5	#6
Compressor Pressure Ratio	\	1.36	1.71	2.07	2.22	2.23	2.23
Compressor Outlet Temp	deg F	149.05	200.46	240.46	252.92	263.94	282.25
Intake Manifold Air Temp	deg F	75.74	81.27	83.25	89.23	93.89	95.72
Intake Manifold Air Density	lb/in3	0.000057	0.000071	0.000085	0.000099	0.000089	0.000088
Density Ratio (Intercooled)	\	1.34	1.67	2.01	2.12	2.1	2.09
Actual Flow Rate (Not Corrected)	lb/min	5.89	12.29	20.69	27.32	34.13	39.69
Actual Flow Rate (Not Corrected)	cfm	85.4	178.13	300.03	396.14	494.94	575.52
Correct Air Flow Rate	lb/min	5.94	12.4	20.91	27.67	34.64	40.33
Correct Air Flow Rate	kg/sec	0.045	0.094	0.158	0.209	0.262	0.305
Correct Air Flow Rate	kg/hr	161	337	568	752	941	1096
Correct Air Flow Rat	m3/sec	0.041	0.085	0.143	0.189	0.237	0.276
1/BSAC	hp-min/lb	12	11.5	10.8	10.3	9.9	9.3
Turbo Shaft Power	Hp	2.49	8.79	19.49	27.74	36.8	46.94
Engine Power	Hp	71.5	142.4	224.9	285.1	342.5	376.5
Torque	lb-ft	187.67	249.36	295.31	299.45	299.78	282.5
Fuel Requirement	lb/hr	30.7	64.1	108	142.5	178.1	207.1

TURBINE MATCH OUTPUTS

Exhaust Manifold Pressure	psi	3.2	6.6	10.9	14.4	17.7	21.4
Engine Delta Pressure (dP)	psi	2	3	4	3	-1	-4
Turbine Swallowing Parameter	PHI	0.0219	0.0213	0.0258	0.0267	0.0283	0.0287
Turbine Corrected Flow @ 59F	lb/min	9.2	15.2	18.4	19	20.2	20.5
Is the Wastegate Flow Choked	\	No	No	No	No	Yes	Yes
Wastegate Flow Area @ CF=0.8	in2	0.03	0.13	0.44	0.73	0.96	1.11
Port Diameter Requirement	mm	5	11	19	24	28	30

Text-Based Output is Provided as Well as Graphical Mapping

THE MATCH-BOT INTERACTIVE TOOL CAN BE FOUND AT:
borgwarnerboosted.com

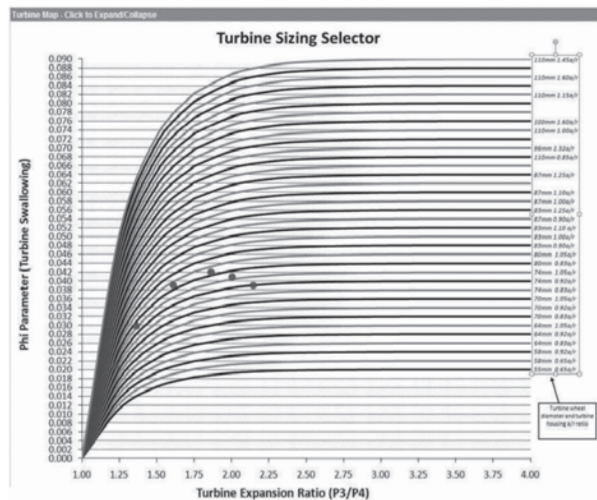
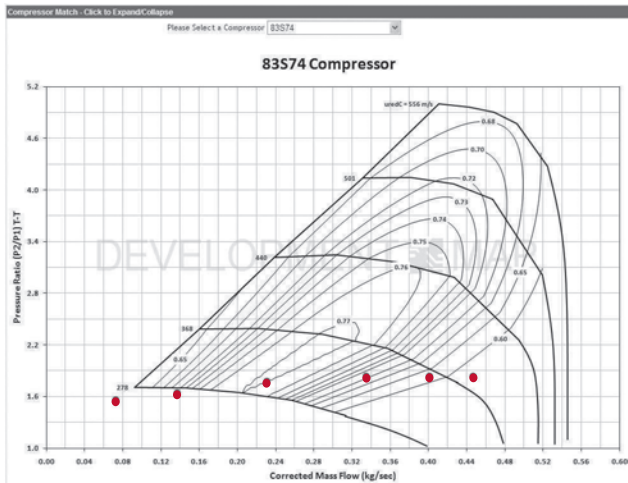

An Equation for Engine Boosting Excellence



Team: Solo Motorsports
Driver: Tony Fuentes
Vehicle: BMW 135i
Racing Venue: Global Time Attack
Current Turbo of choice: EFR-8374

Team: Ryan Litteral Racing
Driver: Ryan Litteral
Vehicle: 1998 Nissan 240SX
Racing Venue: Formula Drift
Current Turbo of choice: EFR-8374



So, you're probably wondering, "What does a new product line of high-performance turbochargers have to do with commercial applications?" The answer lies in the fact that commercial/industrial turbo products have extreme requirements for durability, reliability, and aerodynamic performance. Since modern passenger car applications use turbos smaller than 55mm in turbine wheel diameter, it's the aerodynamic development from the commercial side of the business (i.e. everything larger) that feeds into the performance enthu-

siast's desire for big power production. Boost pressures of 45-50 psi (3 bar+) are the norm, not the exception. Also required is resistance to abusive thrust loads, high vibrations, and robustness for a wide range of lubrication conditions. Additionally, our commercial product validation standards are among the highest in the engine boosting industry - all good things that also benefit the performance enthusiast or racer. Those are the commonalities, but there are also differences. Unlike commercial applications, high performance users want

lightweight, compact, versatile designs. They also deliver the turbocharger very high exhaust gas temperatures with high expectations for fast response. Cosmetic appearance is also valued as are integrated features that aid the installation process and remove the need for other turbo related accessories. Those performance and packaging requirements are quite common among the modern aftermarket passenger car turbo customer.

So, what happens when you combine all of those necessities and put them in front of passionate car people looking to advance the pace of aftermarket boosting solutions? You discover that something new is required to meet the demands of the next generation turbo consumer. There is a fierce desire to take engine boosting to the next level. It was this need for big power that led to EFR.



EFR 58mm and 80mm Gamma-Ti turbine wheels

E F R P R O D U C T F E A T U R E S E T

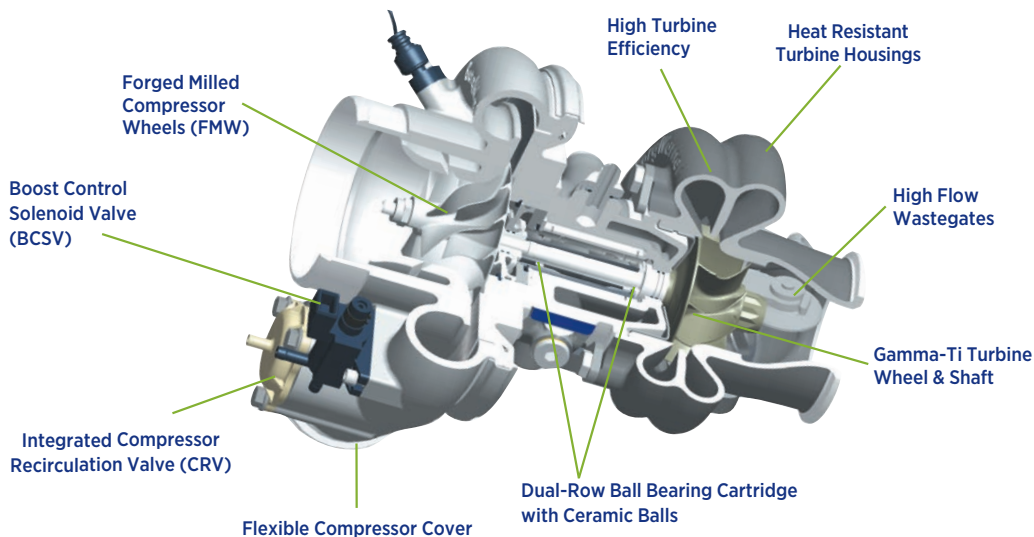

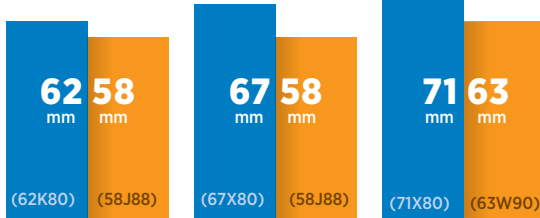

B1

COMPRESSOR
TURBINE



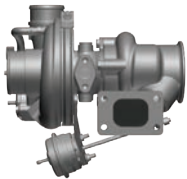
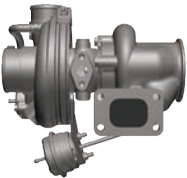

FRAME SIZE ▶	B1	B1	B1
--------------	----	----	----

	450hp	500hp	550hp
Super-Core, Aluminum	11587105002	11587105001	11637105000
Super-Core, Iron	179140	179375	
 <p>A-TYPE B1 Frame Size 0.64 A/R, T25 Flange Single Scroll Wastegated</p>	<p>179150 11581009006</p>	<p>179388 11581009006</p>	
 <p>F-TYPE B1 Frame Size 0.85 A/R, T25 Flange Single Scroll Wastegated</p>		<p>11589880034 11581008000</p>	<p>11639880005 11631008000</p>
 <p>F(v)-TYPE B1 Frame Size 0.85 A/R, V-Band Inlet Single Scroll Wastegated</p>		<p>11589880035 11581008001</p>	<p>11639880006 11631008001</p>
 <p>G-TYPE B1 Frame Size 0.80 A/R, T4 Flange Twin Scroll Wastegated</p>	<p>11589880036 11581008002</p>	<p>11589880037 11581008002</p>	<p>11639880002 11631008002</p>
 <p>I-TYPE B1 Frame Size 0.85 A/R, V-Band Inlet Single Scroll Non-Wastegated</p>		<p>sold as turbine housing kit 11581008003</p>	<p>sold as turbine housing kit 11631008003</p>

B2

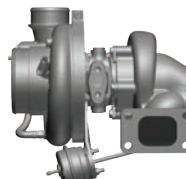
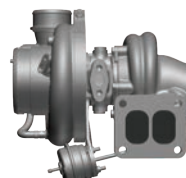
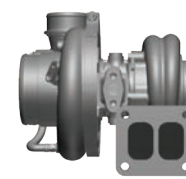
FRAME SIZE ▶	B2
--------------	----

	B2
Super-Core, Aluminum	
Super-Core, Iron	
 <p>B-TYPE B2 Frame Size 0.83 A/R, T3 Flange Single Scroll Wastegated</p>	
 <p>C-TYPE B2 Frame Size 0.92 A/R, T4 Flange Twin Scroll Wastegated</p>	
 <p>D-TYPE B2 Frame Size 1.05 A/R, T4 Flange Twin Scroll Non-Wastegated</p>	
 <p>H-TYPE B2 Frame Size 1.45 A/R, T4 Flange Twin Scroll Non-Wastegated</p>	

	70 mm (70S75)	64 mm (64J88)	76 mm (76S75)	70 mm (70J88)	83 mm (83S75)	74 mm (74A87)	84 mm (84X80)	74 mm (74A87)	91 mm (91S74)	74 mm (74A87)	92 mm (92X79)	74 mm (74A87)	91 mm (91S74)	80 mm (80M92)	92 mm (92X81)	80 mm (80M92)
	B2		B2		B2		B2		B2		B2		B2		B2	
	550hp		650hp		750hp		950hp		1000hp		1050hp		1000hp		1100hp	
	12709097006		12769097001		12839097000		12747100017		12919097000		12747100021		12919097001		12807100003	
	179354		179350		179257		12747100019		12919097002		12747100023		179356		12807100005	
	179355 12641008006		179351 12701008014		179258 12741008000		12741008000		12741008000		12741008000		179358 12801008002		12801008002	
	179389 12641008007		179390 12701008016		179357 12741008001		12741008001		12741008001		12741008001		12809880000 12801019009		12801019009	
	179391 12641019016		179392 12701019047		179393 12741019002		12741019002		12741019002		12741019002		179394 12801019001		12801019001	
					sold as turbine housing kit 12741008003		sold as turbine housing kit 12741008003		sold as turbine housing kit 12741008003		sold as turbine housing kit 12741008003		sold as turbine housing kit 12801008006		sold as turbine housing kit 12801008006	

Turbo Assembly
Turbine Housing Assembly

K E Y

EFR 6258-A

225-450 HP Turbo

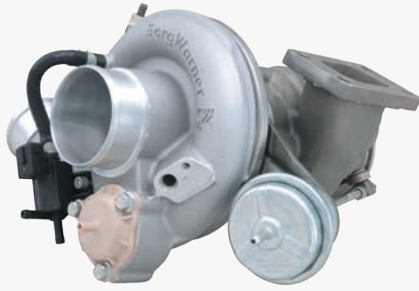

EFR 6258-G

225-450 HP Turbo



F E A T U R E S

- Gamma-Ti turbine wheel
- Integrated Compressor Recirculation Valve (CRV)
- Dual ceramic ball bearing assembly with metal cage
- Boost Control Solenoid Valve (BCSV)
- Forged Milled Compressor Wheel (FMW)
- Extended tip technology
- Compressor cover with speed sensor mounting provisions

Product - (TYPE)	Complete Turbo	Bearing Housing Material	Super-Core**	TURBINE HOUSING				
				Assembly	A/R	Inlet	Scroll	Waste-gate
6258-A	179150	Iron	179140	11581009006	0.64	T25	Single	Yes
6258-F	-	-	-	-	-	-	-	-
6258-F(v)	-	-	-	-	-	-	-	-
6258-G	11589880036	Aluminum*	11587105002	11581008002	0.80	T4	Dual	Yes
6258-I	-	-	-	-	-	-	-	-
6258	-	Aluminum*	11587105002	-	-	-	-	-
6258	-	Iron	179140	-	-	-	-	-

Turbo Frame Size	B1
Comp. Wheel Inducer Dia. (mm)	49
Comp. Wheel Outer Dia. (mm)	62
Turbine Wheel Exducer Dia. (mm)	51
Turbine Wheel Outer Dia. (mm)	58

*Aluminum bearing housings require cooling

**The following components are not included as part of the Super-Core: Turbine Housing, Clamp Plate Hardware, Wastegate, and Actuator

COMPRESSOR MAP / APPLICABLE TO ALL 6258 UNITS

Comp. Wheel Inducer Dia. (mm) 49
Comp. Wheel Outer Dia. (mm) 62

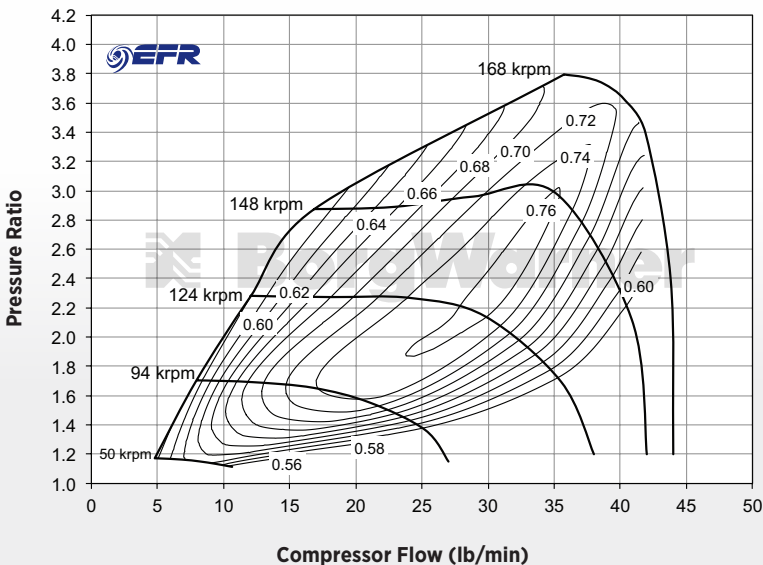

OPTIONAL HARDWARE

See page 37 for: Speed Sensor, Turbine Gaskets & V-Bands, Oil Drain Gasket & Fitting, Actuators & Brackets



Compressor Cover SX-E Style	Compressor Cover with 90° Outlet	I-Type Turbine Housing
11621013032	11621003002	11581008003

SEE PAGE 34 FOR FRAME DIMENSIONS

SEE PAGE 61 FOR SPEED SENSOR INSTALLATION DETAILS

EFR 6758-A

250 - 500 HP Turbo



EFR 6758-F

250 - 500 HP Turbo



EFR 6758-F(v)

250 - 500 HP Turbo



EFR 6758-G

250 - 500 HP Turbo



F E A T U R E S

- Gamma-Ti turbine wheel
- Integrated Compressor Recirculation Valve (CRV)
- Dual ceramic ball bearing assembly with metal cage
- Boost Control Solenoid Valve (BCSV)
- Forged Milled Compressor Wheel (FMW)
- Extended tip technology
- Compressor cover with speed sensor mounting provisions

Product - (TYPE)	Complete Turbo	Bearing Housing Material	Super-Core**	TURBINE HOUSING				
				Assembly	A/R	Inlet	Scroll	Wastegate
6758-A	179388	Iron	179375	11581009006	0.64	T25	Single	Yes
6758-F	11589880034	Aluminum*	11587105001	11581008000	0.85	T25	Single	Yes
6758-F(v)	11589880035	Aluminum*	11587105001	11581008001	0.85	V-Band	Single	Yes
6758-G	11589880037	Aluminum*	11587105001	11581008002	0.80	T4	Twin	Yes
6758-I	-	-	-	11581008003	0.85	V-Band	Single	No
6758	-	Aluminum*	11587105001	-	-	-	-	-
6758	-	Iron	179375	-	-	-	-	-

Turbo Frame Size	B1
Comp. Wheel Inducer Dia. (mm)	54
Comp. Wheel Outer Dia. (mm)	67
Turbine Wheel Exducer Dia. (mm)	51
Turbine Wheel Outer Dia. (mm)	58

*Aluminum bearing housings require cooling

**The following components are not included as part of the Super-Core: Turbine Housing, Clamp Plate Hardware, Wastegate, and Actuator

COMPRESSOR MAP / APPLICABLE TO ALL 6758 UNITS

Comp. Wheel Inducer Dia. (mm) 54
Comp. Wheel Outer Dia. (mm) 67

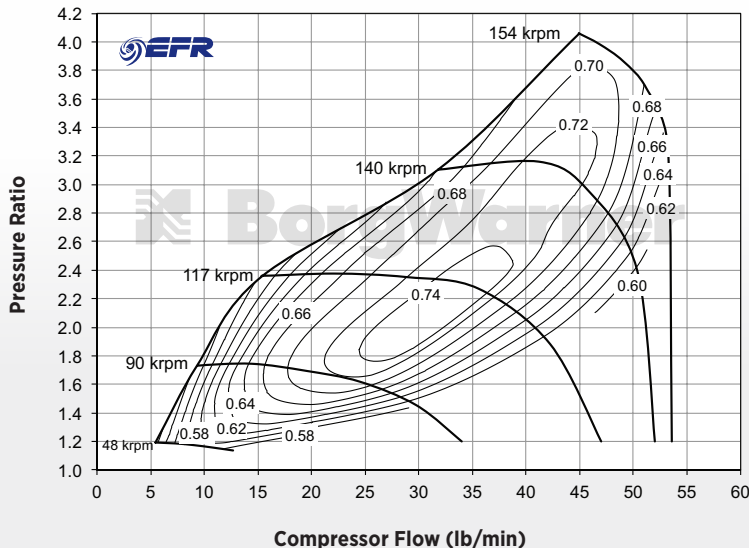

OPTIONAL HARDWARE

See page 37 for: Speed Sensor, Turbine Gaskets & V-Bands, Oil Drain Gasket & Fitting, Actuators & Brackets



Compressor Cover SX-E Style	Compressor Cover with 90° Outlet	I-Type Turbine Housing
11671013004	11671003001	11581008003

SEE PAGE 34 FOR FRAME DIMENSIONS

SEE PAGE 61 FOR SPEED SENSOR INSTALLATION DETAILS

EFR 7163-F

300 - 550 HP Turbo



EFR 7163-F(v)

300 - 550 HP Turbo



EFR 7163-G

300 - 550 HP Turbo



F E A T U R E S

- Gamma-Ti turbine wheel
- Integrated Compressor Recirculation Valve (CRV)
- Dual ceramic ball bearing assembly with metal cage
- Boost Control Solenoid Valve (BCSV)
- Forged Milled Compressor Wheel (FMW)
- Extended tip technology
- Compressor cover with speed sensor mounting provisions

Product - (TYPE)	Complete Turbo	Bearing Housing Material	Super-Core**	TURBINE HOUSING				
				Assembly	A/R	Inlet	Scroll	Waste-gate
7163-F	11639880005	Aluminum*	11637105000	11631008000	0.85	T25	Single	Yes
7163-F(v)	11639880006	Aluminum*	11637105000	11631008001	0.85	V-Band	Single	Yes
7163-G	11639880002	Aluminum*	11637105000	11631008002	0.80	T4	Twin	Yes
7163-I	-	-	-	11631008003	0.85	V-Band	Single	No
7163	-	Aluminum*	11637105000	-	-	-	-	-

Turbo Frame Size	B1
Comp. Wheel Inducer Dia. (mm)	57
Comp. Wheel Outer Dia. (mm)	71
Turbine Wheel Exducer Dia. (mm)	56
Turbine Wheel Outer Dia. (mm)	63

*Aluminum bearing housings require cooling

**The following components are not included as part of the Super-Core: Turbine Housing, Clamp Plate Hardware, Wastegate, and Actuator

COMPRESSOR MAP / APPLICABLE TO ALL 7163 UNITS

Comp. Wheel Inducer Dia. (mm) 57
Comp. Wheel Outer Dia. (mm) 71

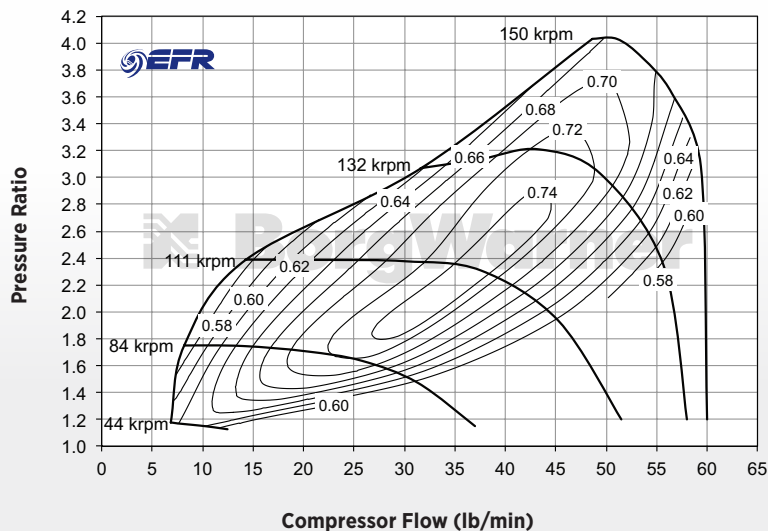

OPTIONAL HARDWARE

See page 37 for: Speed Sensor, Turbine Gaskets & V-Bands, Oil Drain Gasket & Fitting, Actuators & Brackets



Compressor Cover SX-E Style	Compressor Cover with 90° Outlet	I-Type Turbine Housing
11711013004	11711003001	11631008003

SEE PAGE 34 FOR FRAME DIMENSIONS

SEE PAGE 61 FOR SPEED SENSOR INSTALLATION DETAILS

EFR 7064-B

300 - 550 HP Turbo



EFR 7064-C

300 - 550 HP Turbo

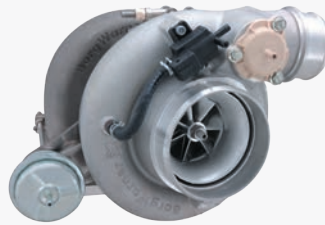

EFR 7064-D

300 - 550 HP Turbo



FEATURES

- Gamma-Ti turbine wheel
- Integrated Compressor Recirculation Valve (CRV)
- Dual ceramic ball bearing assembly with metal cage
- Boost Control Solenoid Valve (BCSV)
- Forged Milled Compressor Wheel (FMW)
- Extended tip technology
- Compressor cover with speed sensor mounting provisions

Product - (TYPE)	Complete Turbo	Bearing Housing Material	Super-Core**	TURBINE HOUSING				
				Assembly	A/R	Inlet	Scroll	Waste-gate
7064-B	179355	Iron	179354	12641008006	0.83	T3	Single	Yes
7064-C	179389	Iron	179354	12641008007	0.92	T4	Twin	Yes
7064-D	179391	Iron	179354	12641019016	1.05	T4	Twin	No
7064	-	Aluminum*	12709097006	-	-	-	-	-
7064	-	Iron	179354	-	-	-	-	-

Turbo Frame Size	B2
Comp. Wheel Inducer Dia. (mm)	52
Comp. Wheel Outer Dia. (mm)	70
Turbine Wheel Exducer Dia. (mm)	56
Turbine Wheel Outer Dia. (mm)	64

*Aluminum bearing housings require cooling

**The following components are not included as part of the Super-Core: Turbine Housing, Clamp Plate Hardware, Wastegate, and Actuator

COMPRESSOR MAP / APPLICABLE TO ALL 7064 UNITS

Comp. Wheel Inducer Dia. (mm) 52
Comp. Wheel Outer Dia. (mm) 70

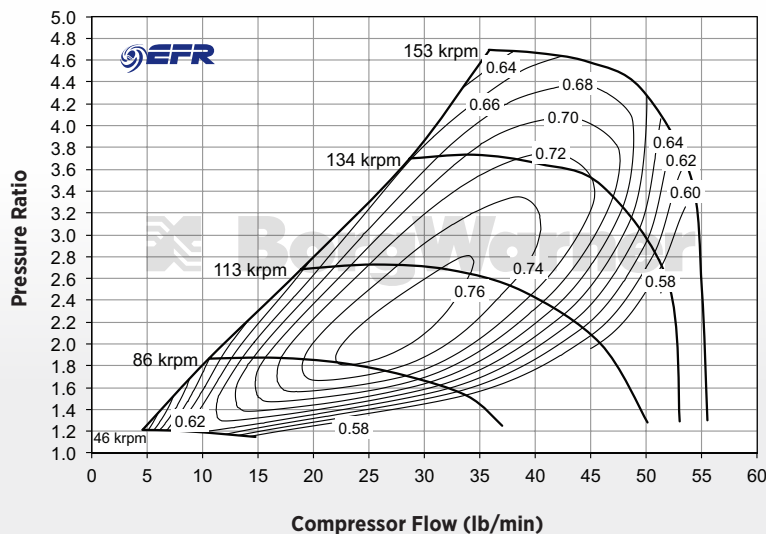

OPTIONAL HARDWARE

See page 37 for: Speed Sensor, Turbine Gaskets & V-Bands, Oil Drain Gasket & Fitting, Actuators & Brackets



Compressor Cover SX-E Style

12701013022

SEE PAGE 35 FOR FRAME DIMENSIONS

SEE PAGE 61 FOR SPEED SENSOR INSTALLATION DETAILS

EFR 7670-B

375 - 650 HP Turbo

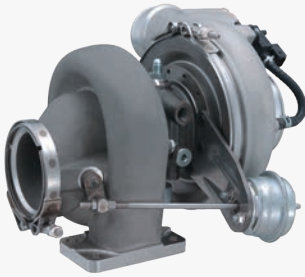

EFR 7670-C

375 - 650 HP Turbo



EFR 7670-D

375 - 650 HP Turbo



FEATURES

- Gamma-Ti turbine wheel
- Integrated Compressor Recirculation Valve (CRV)
- Dual ceramic ball bearing assembly with metal cage
- Boost Control Solenoid Valve (BCSV)
- Forged Milled Compressor Wheel (FMW)
- Extended tip technology
- Compressor cover with speed sensor mounting provisions

Product - (TYPE)	Complete Turbo	Bearing Housing Material	Super-Core**	TURBINE HOUSING				
				Assembly	A/R	Inlet	Scroll	Waste-gate
7670-B	179351	Iron	179350	12701008014	0.83	T3	Single	Yes
7670-C	179390	Iron	179350	12701008016	0.92	T4	Twin	Yes
7670-D	179392	Iron	179350	12701019047	1.05	T4	Twin	No
7670	-	Aluminum*	12769097001	-	-	-	-	-
7670	-	Iron	179350	-	-	-	-	-

Turbo Frame Size	B2
Comp. Wheel Inducer Dia. (mm)	57
Comp. Wheel Outer Dia. (mm)	76
Turbine Wheel Exducer Dia. (mm)	61
Turbine Wheel Outer Dia. (mm)	70

*Aluminum bearing housings require cooling

**The following components are not included as part of the Super-Core: Turbine Housing, Clamp Plate Hardware, Wastegate, and Actuator

COMPRESSOR MAP / APPLICABLE TO ALL 7670 UNITS

Comp. Wheel Inducer Dia. (mm) 57
Comp. Wheel Outer Dia. (mm) 76

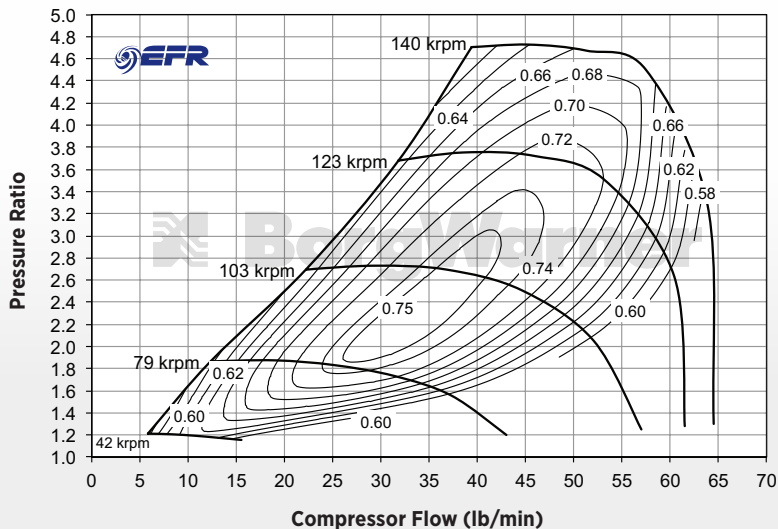

OPTIONAL HARDWARE

See page 37 for: Speed Sensor, Turbine Gaskets & V-Bands, Oil Drain Gasket & Fitting, Actuators & Brackets



Compressor Cover SX-E Style

12761013034

SEE PAGE 35 FOR FRAME DIMENSIONS

SEE PAGE 61 FOR SPEED SENSOR INSTALLATION DETAILS

EFR 8374-B

475 - 750 HP Turbo

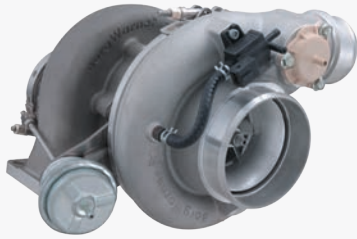

EFR 8374-C

475 - 750 HP Turbo



EFR 8374-D

475 - 750 HP Turbo



F E A T U R E S

- Gamma-Ti turbine wheel
- Integrated Compressor Recirculation Valve (CRV)
- Dual ceramic ball bearing assembly with metal cage
- Boost Control Solenoid Valve (BCSV)
- Forged Milled Compressor Wheel (FMW)
- Extended tip technology
- Compressor cover with speed sensor mounting provisions

Product - (TYPE)	Complete Turbo	Bearing Housing Material	Super-Core**	TURBINE HOUSING				
				Assembly	A/R	Inlet	Scroll	Waste-gate
8374-B	179258	Iron	179257	12741008000	0.83	T3	Single	Yes
8374-C	179357	Iron	179257	12741008001	0.92	T4	Twin	Yes
8374-D	179393	Iron	179257	12741019002	1.05	T4	Twin	No
8374-H	-	-	-	12741008003	1.45	T4	Twin	No
8374	-	Aluminum*	12839097000	-	-	-	-	-
8374	-	Iron	179257	-	-	-	-	-

Turbo Frame Size	B2
Comp. Wheel Inducer Dia. (mm)	62
Comp. Wheel Outer Dia. (mm)	84
Turbine Wheel Exducer Dia. (mm)	65
Turbine Wheel Outer Dia. (mm)	74

*Aluminum bearing housings require cooling

**The following components are not included as part of the Super-Core: Turbine Housing, Clamp Plate Hardware, Wastegate, and Actuator

COMPRESSOR MAP / APPLICABLE TO ALL 8374 UNITS

Comp. Wheel Inducer Dia. (mm) 62
Comp. Wheel Outer Dia. (mm) 84

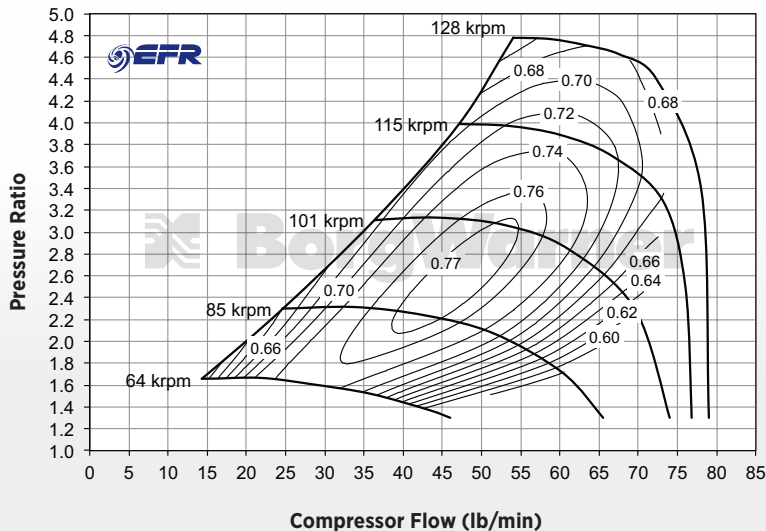

OPTIONAL HARDWARE

See page 37 for: Speed Sensor, Turbine Gaskets & V-Bands, Oil Drain Gasket & Fitting, Actuators & Brackets



Compressor Cover SX-E Style

12831013012



H-Type Turbine Housing

12741008003

SEE PAGE 35 FOR FRAME DIMENSIONS

SEE PAGE 61 FOR SPEED SENSOR INSTALLATION DETAILS

EFR 8474 Aluminum Super-Core

500 - 950 HP

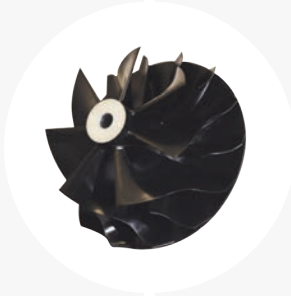

EFR 8474 Iron Super-Core

500 - 950 HP



F E A T U R E S

- Gamma-Ti turbine wheel
- Integrated Compressor Recirculation Valve (CRV)
- Dual ceramic ball bearing assembly with metal cage
- Boost Control Solenoid Valve (BCSV)
- Black Anodized Forged Milled Compressor Wheel (FMW)
- Extended tip technology
- Compressor cover with speed sensor mounting provisions

Product - (TYPE)	Complete Turbo	Bearing Housing Material	Super-Core**	TURBINE HOUSING				
				Assembly	A/R	Inlet	Scroll	Waste-gate
8474-B	-	-	-	12741008000	0.83	T3	Single	Yes
8474-C	-	-	-	12741008001	0.92	T4	Twin	Yes
8474-D	-	-	-	12741019002	1.05	T4	Twin	No
8474-H	-	-	-	12741008003	1.45	T4	Twin	No
8474	-	Aluminum*	12747100017	-	-	-	-	-
8474	-	Iron	12747100019	-	-	-	-	-

Turbo Frame Size	B2
Comp. Wheel Inducer Dia. (mm)	68
Comp. Wheel Outer Dia. (mm)	84
Turbine Wheel Exducer Dia. (mm)	65
Turbine Wheel Outer Dia. (mm)	74

NEW!

*Aluminum bearing housings require cooling

**The following components are not included as part of the Super-Core: Turbine Housing, Clamp Plate Hardware, Wastegate, and Actuator

COMPRESSOR MAP / APPLICABLE TO ALL 8474 UNITS

Comp. Wheel Inducer Dia. (mm) 68
Comp. Wheel Outer Dia. (mm) 84

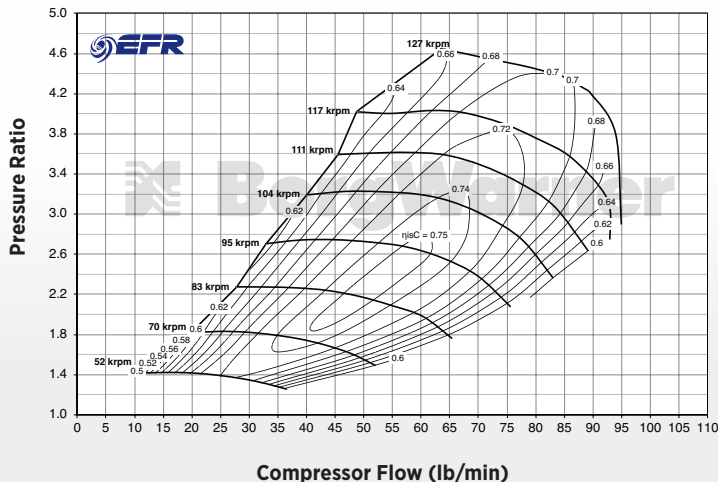

OPTIONAL HARDWARE

See page 37 for: Speed Sensor, Turbine Gaskets & V-Bands, Oil Drain Gasket & Fitting, Actuators & Brackets



H-Type Turbine Housing

12741008003

SEE PAGE 35 FOR FRAME DIMENSIONS

SEE PAGE 61 FOR SPEED SENSOR INSTALLATION DETAILS

EFR 9174 Aluminum Super-Core

600 - 1000 HP Turbo



EFR 9174 Iron Super-Core

600 - 1000 HP Turbo



FEATURES

- Gamma-Ti turbine wheel
- Integrated Compressor Recirculation Valve (CRV)
- Dual ceramic ball bearing assembly with metal cage
- Boost Control Solenoid Valve (BCSV)
- Forged Milled Compressor Wheel (FMW)
- Extended tip technology
- Compressor cover with speed sensor mounting provisions

Product - (TYPE)	Complete Turbo	Bearing Housing Material	Super-Core**	TURBINE HOUSING				
				Assembly	A/R	Inlet	Scroll	Waste-gate
9174-B	-	-	-	12741008000	0.83	T3	Single	Yes
9174-C	-	-	-	12741008001	0.92	T4	Twin	Yes
9174-D	-	-	-	12741019002	1.05	T4	Twin	No
9174-H	-	-	-	12741008003	1.45	T4	Twin	No
9174	-	Aluminum*	12919097000	-	-	-	-	-
9174	-	Iron	12919097002	-	-	-	-	-

Turbo Frame Size	B2
Comp. Wheel Inducer Dia. (mm)	68
Comp. Wheel Outer Dia. (mm)	91
Turbine Wheel Exducer Dia. (mm)	65
Turbine Wheel Outer Dia. (mm)	74

*Aluminum bearing housings require cooling

**The following components are not included as part of the Super-Core: Turbine Housing, Clamp Plate Hardware, Wastegate, and Actuator

COMPRESSOR MAP / APPLICABLE TO ALL 9174 AND 9180 UNITS

Comp. Wheel Inducer Dia. (mm) 68
Comp. Wheel Outer Dia. (mm) 91

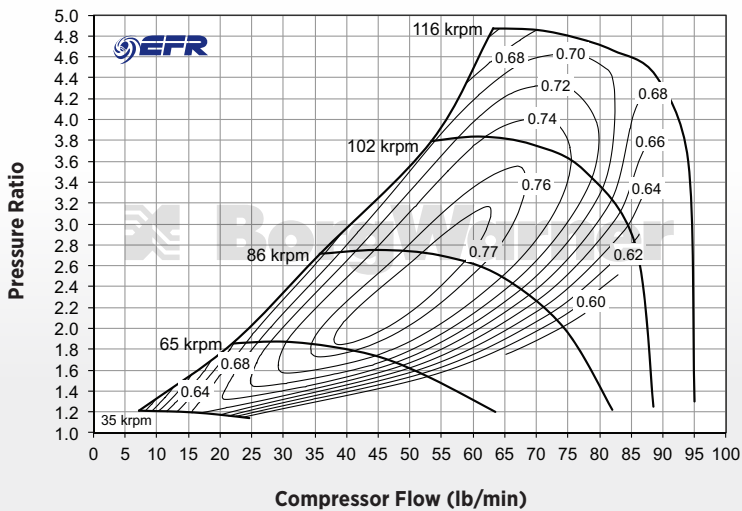

OPTIONAL HARDWARE

See page 37 for: Speed Sensor, Turbine Gaskets & V-Bands, Oil Drain Gasket & Fitting, Actuators & Brackets



Compressor Cover
SX-E Style

12911013005



H-Type
Turbine Housing

12741008003

SEE PAGE 35 FOR FRAME DIMENSIONS

SEE PAGE 61 FOR SPEED SENSOR INSTALLATION DETAILS

EFR 9274 Aluminum Super-Core

600 - 1050 HP



EFR 9274 Iron Super-Core

600 - 1050 HP



FEATURES

- Gamma-Ti turbine wheel
- Integrated Compressor Recirculation Valve (CRV)
- Dual ceramic ball bearing assembly with metal cage
- Boost Control Solenoid Valve (BCSV)
- Black Anodized Forged Milled Compressor Wheel (FMW)
- Extended tip technology
- Compressor cover with speed sensor mounting provisions

NEW!

Product - (TYPE)	Complete Turbo	Bearing Housing Material	Super-Core**	TURBINE HOUSING				
				Assembly	A/R	Inlet	Scroll	Waste-gate
9274-B	-	-	-	12741008000	0.83	T3	Single	Yes
9274-C	-	-	-	12741008001	0.92	T4	Twin	Yes
9274-D	-	-	-	12741019002	1.05	T4	Twin	No
9274-H	-	-	-	12741008003	1.45	T4	Twin	No
9274	-	Aluminum*	12747100021	-	-	-	-	-
9274	-	Iron	12747100023	-	-	-	-	-

Turbo Frame Size	B2
Comp. Wheel Inducer Dia. (mm)	72
Comp. Wheel Outer Dia. (mm)	91
Turbine Wheel Exducer Dia. (mm)	65
Turbine Wheel Outer Dia. (mm)	74

*Aluminum bearing housings require cooling

**The following components are not included as part of the Super-Core: Turbine Housing, Clamp Plate Hardware, Wastegate, and Actuator

COMPRESSOR MAP / APPLICABLE TO ALL 9274 UNITS

Comp. Wheel Inducer Dia. (mm) 72
Comp. Wheel Outer Dia. (mm) 91

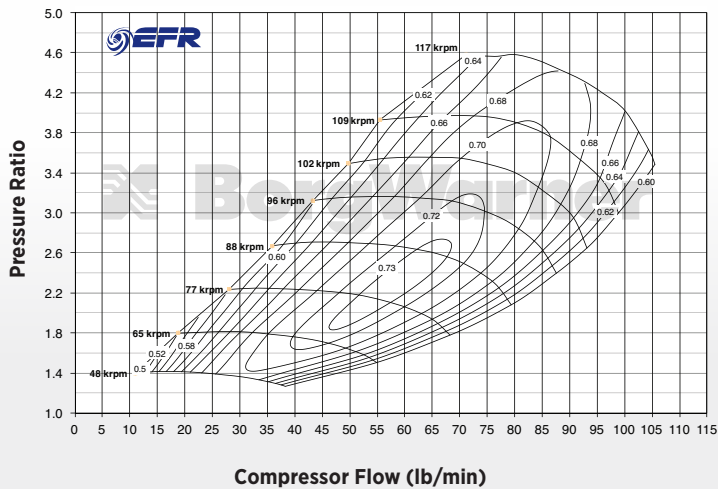

OPTIONAL HARDWARE

See page 37 for: Speed Sensor, Turbine Gaskets & V-Bands, Oil Drain Gasket & Fitting, Actuators & Brackets



H-Type Turbine Housing

12741008003

SEE PAGE 35 FOR FRAME DIMENSIONS

SEE PAGE 61 FOR SPEED SENSOR INSTALLATION DETAILS

EFR 9180-B

600 - 1000 HP Turbo



EFR 9180-C

600 - 1000 HP Turbo



EFR 9180-D

600 - 1000 HP Turbo

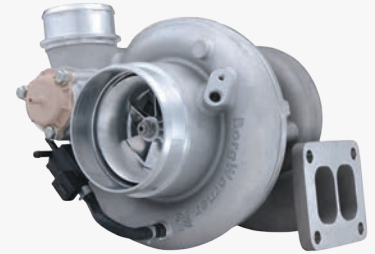

FEATURES

- Gamma-Ti turbine wheel
- Integrated Compressor Recirculation Valve (CRV)
- Dual ceramic ball bearing assembly with metal cage
- Boost Control Solenoid Valve (BCSV)
- Forged Milled Compressor Wheel (FMW)
- Extended tip technology
- Compressor cover with speed sensor mounting provisions

Product - (TYPE)	Complete Turbo	Bearing Housing Material	Super-Core**	TURBINE HOUSING				
				Assembly	A/R	Inlet	Scroll	Waste-gate
9180-B	179358	Iron	179356	12801008002	0.83	T3	Single	Yes
9180-C	12809880000	Iron	179356	12801019009	0.92	T4	Twin	Yes
9180-D	179394	Iron	179356	12801019001	1.05	T4	Twin	No
9180-H	-	-	-	12801008006	1.45	T4	Twin	No
9180	-	Aluminum*	12919097001	-	-	-	-	-
9180	-	Iron	179356	-	-	-	-	-

Turbo Frame Size	B2
Comp. Wheel Inducer Dia. (mm)	68
Comp. Wheel Outer Dia. (mm)	91
Turbine Wheel Exducer Dia. (mm)	73
Turbine Wheel Outer Dia. (mm)	80

*Aluminum bearing housings require cooling

**The following components are not included as part of the Super-Core: Turbine Housing, Clamp Plate Hardware, Wastegate, and Actuator

COMPRESSOR MAP / APPLICABLE TO ALL 9174 AND 9180 UNITS

Comp. Wheel Inducer Dia. (mm) 68
Comp. Wheel Outer Dia. (mm) 91

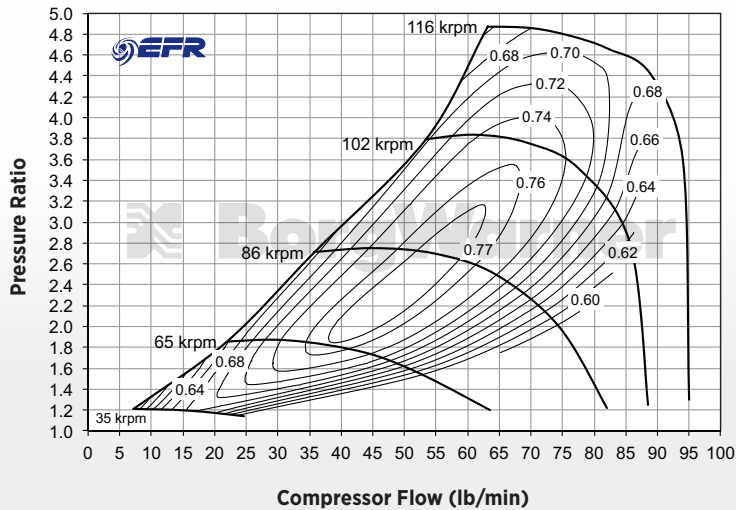

OPTIONAL HARDWARE

See page 37 for: Speed Sensor, Turbine Gaskets & V-Bands, Oil Drain Gasket & Fitting, Actuators & Brackets



Compressor Cover
SX-E Style

12911013005



H-Type
Turbine Housing

12801008006

SEE PAGE 35 FOR FRAME DIMENSIONS

SEE PAGE 61 FOR SPEED SENSOR INSTALLATION DETAILS

EFR 9280 Aluminum Super-Core

600 - 1100 HP

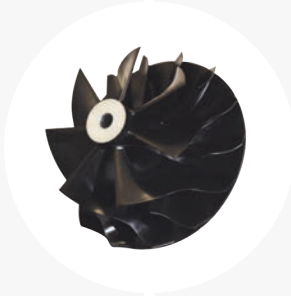

EFR 9280 Iron Super-Core

600 - 1100 HP



F E A T U R E S

- Gamma-Ti turbine wheel
- Integrated Compressor Recirculation Valve (CRV)
- Dual ceramic ball bearing assembly with metal cage
- Boost Control Solenoid Valve (BCSV)
- Black Anodized Forged Milled Compressor Wheel (FMW)
- Extended tip technology
- Compressor cover with speed sensor mounting provisions

Product - (TYPE)	Complete Turbo	Bearing Housing Material	Super-Core**	TURBINE HOUSING				
				Assembly	A/R	Inlet	Scroll	Waste-gate
9280-B	-	-	-	12801008002	0.83	T3	Single	Yes
9280-C	-	-	-	12801019009	0.92	T4	Twin	Yes
9280-D	-	-	-	12801019001	1.05	T4	Twin	No
9280-H	-	-	-	12801008006	1.45	T4	Twin	No
9280	-	Aluminum*	12807100003	-	-	-	-	-
9280	-	Iron	12807100005	-	-	-	-	-

Turbo Frame Size	B2
Comp. Wheel Inducer Dia. (mm)	74
Comp. Wheel Outer Dia. (mm)	91
Turbine Wheel Exducer Dia. (mm)	73
Turbine Wheel Outer Dia. (mm)	80

NEW!

*Aluminum bearing housings require cooling

**The following components are not included as part of the Super-Core: Turbine Housing, Clamp Plate Hardware, Wastegate, and Actuator

COMPRESSOR MAP / APPLICABLE TO ALL 9280 UNITS

Comp. Wheel Inducer Dia. (mm) 72
Comp. Wheel Outer Dia. (mm) 91

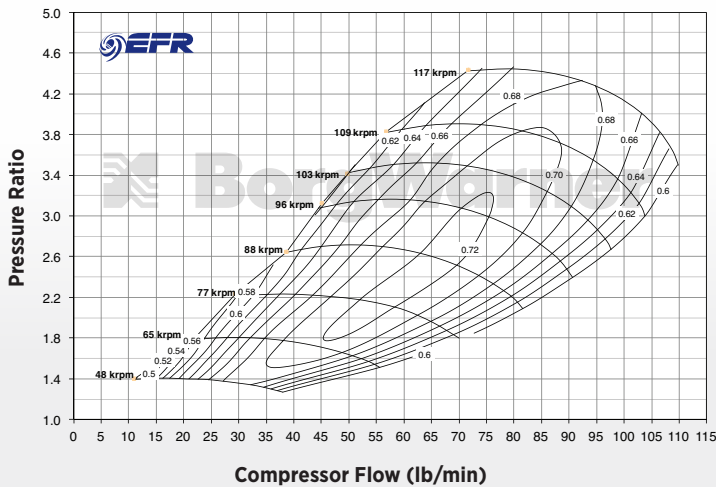

OPTIONAL HARDWARE

See page 37 for: Speed Sensor, Turbine Gaskets & V-Bands, Oil Drain Gasket & Fitting, Actuators & Brackets



H-Type Turbine Housing

12801008006

SEE PAGE 35 FOR FRAME DIMENSIONS

SEE PAGE 61 FOR SPEED SENSOR INSTALLATION DETAILS

The right turbo for you.

This example shown below illustrates how to select part numbers to create a highly optioned EFR 9174-C turbo.

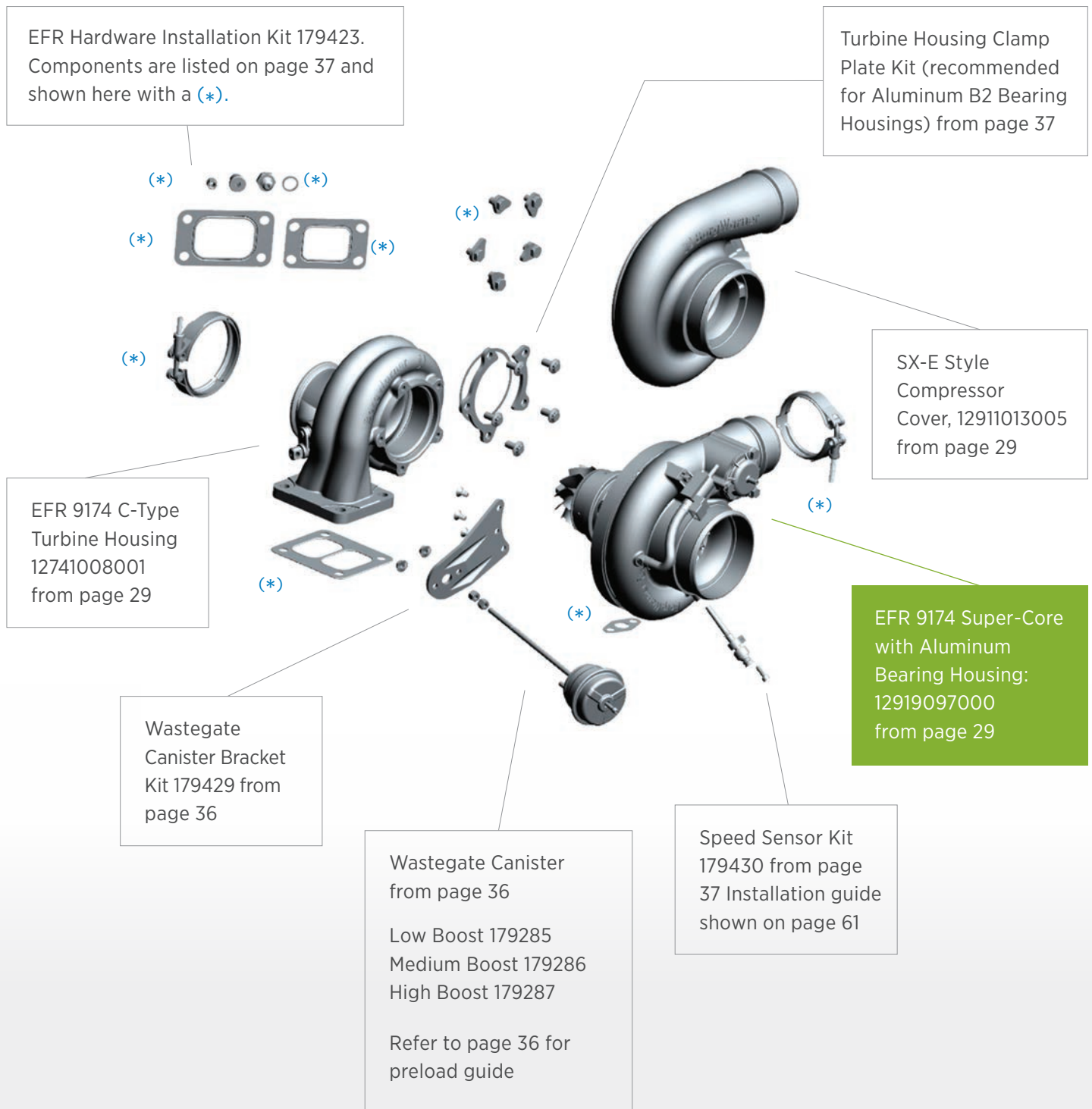

Turbo Frame Dimensions

For all 6258 / 6758 / 7163 EFR models.*

B1

FRAME SIZE

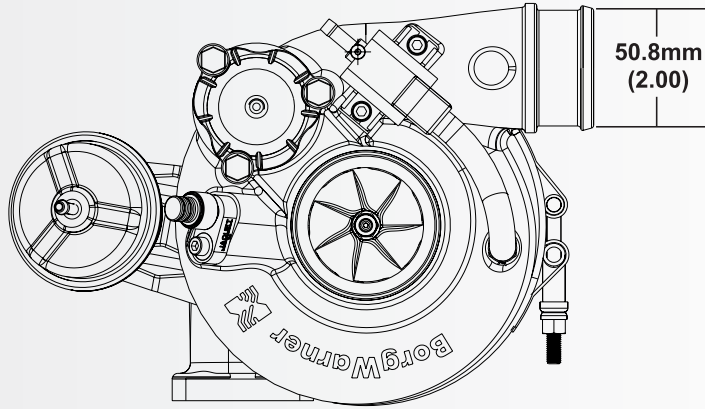

50.8mm
(2.00)

*Speed sensor details, see page 61

A & F - TYPE

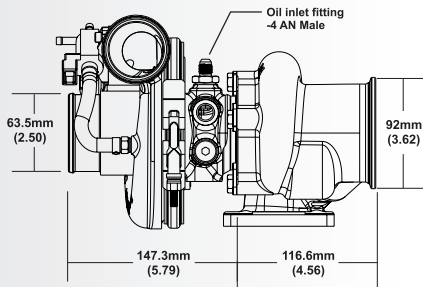

63.5mm
(2.50)

147.3mm
(5.79)

116.6mm
(4.56)

Oil inlet fitting
-4 AN Male

92mm
(3.62)

F (V) & I - TYPE

Note: I-type is not wastegated

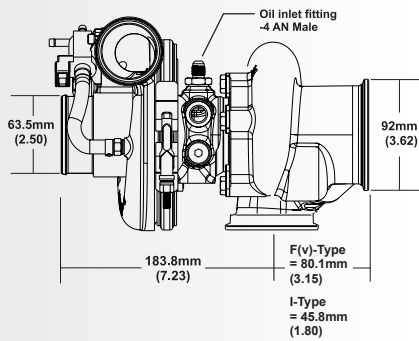

63.5mm
(2.50)

183.8mm
(7.23)

92mm
(3.62)

Oil inlet fitting
-4 AN Male

F(v)-Type
= 80.1mm
(3.15)

I-Type
= 45.8mm
(1.80)

G - TYPE

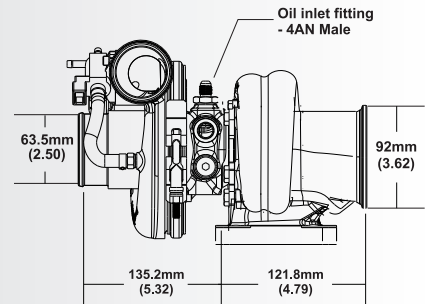

63.5mm
(2.50)

135.2mm
(5.32)

121.8mm
(4.79)

Oil inlet fitting
-4AN Male

92mm
(3.62)

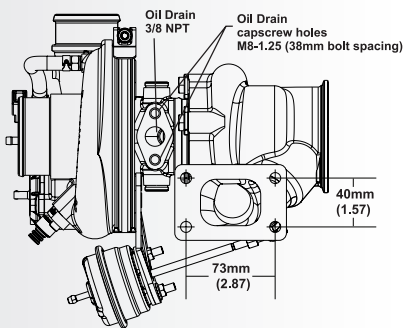

73mm
(2.87)

40mm
(1.57)

Oil Drain
3/8 NPT

Oil Drain
capscrew holes
M8-1.25 (38mm bolt spacing)

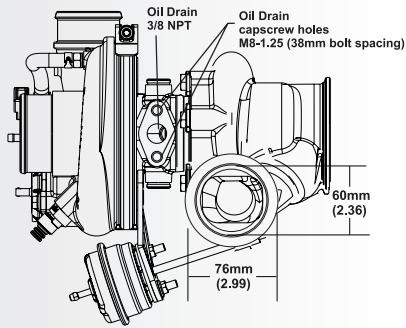

76mm
(2.99)

60mm
(2.36)

Oil Drain
3/8 NPT

Oil Drain
capscrew holes
M8-1.25 (38mm bolt spacing)

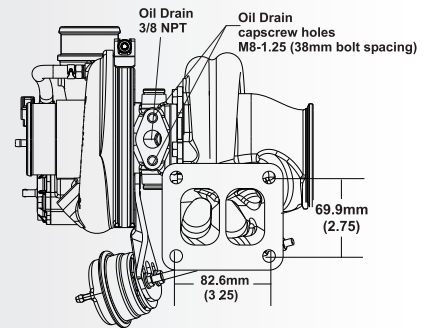

82.6mm
(3.25)

69.9mm
(2.75)

Oil Drain
3/8 NPT

Oil Drain
capscrew holes
M8-1.25 (38mm bolt spacing)

Turbo Frame Dimensions

For all 7064 / 7670 / 8374 / 8474 / 9174 / 9274 / 9180 and 9280 EFR models.*

B2 FRAME SIZE

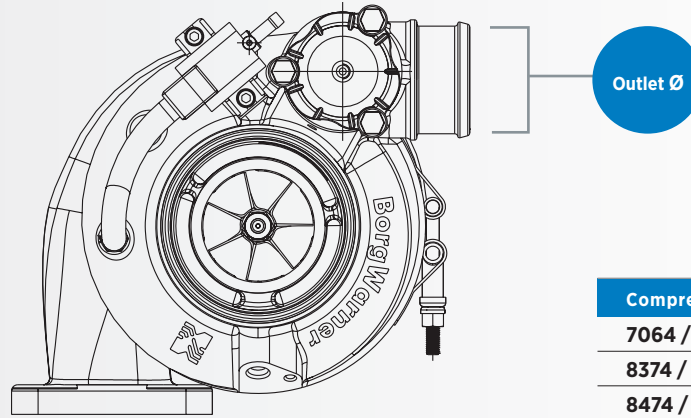

Compressor Outlet Ø

7064 / 7670 = 50.8mm (2.00)

8374 / 9174 / 9180 = 63.5mm (2.50)

8474 / 9274 / 9280 = 63.5mm (2.50)

*Speed sensor details, see page 61

B - TYPE

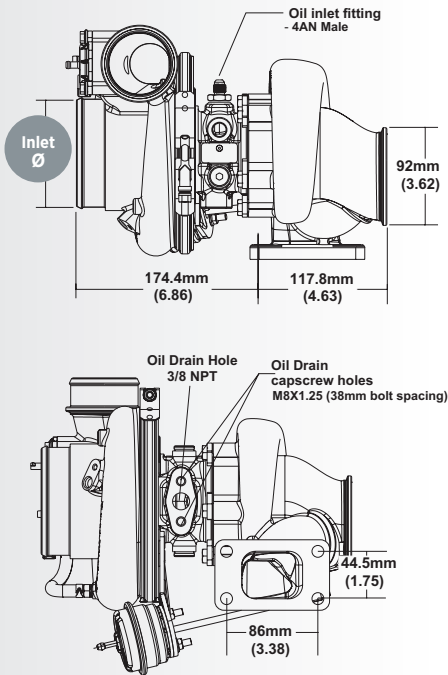

C - TYPE

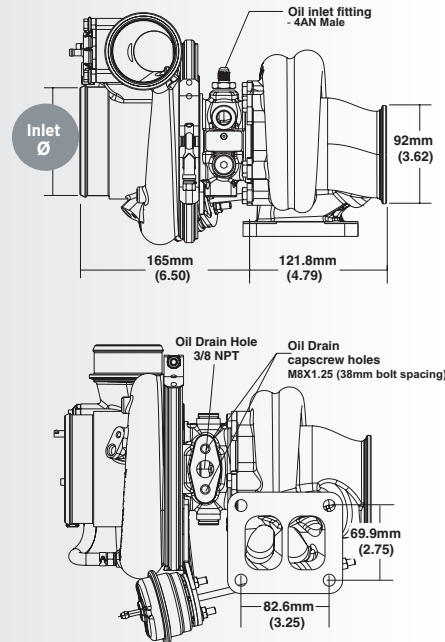

D & H - TYPE

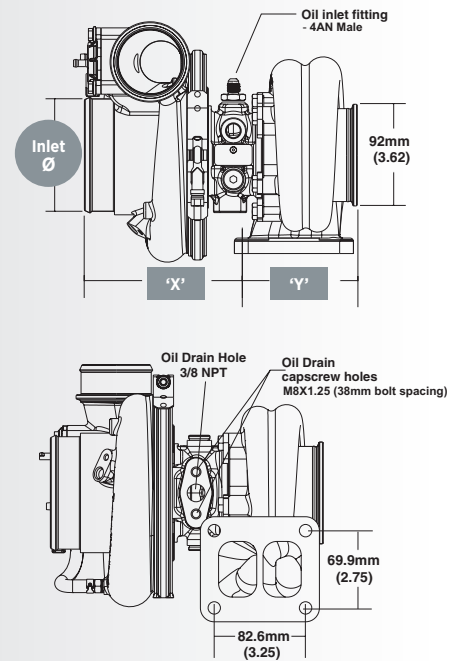

Compressor Inlet Ø

7064 / 7670 = 88.9mm (3.50)

8374 / 9174 / 9180 = 101.6mm (4.00)

8474 / 9274 / 9280 = 101.6mm (4.00)

Dimension 'X'

7064 / 7670 D-Type = 142mm (5.60)

8374 / 9180 D-Type = 148mm (5.82)

8374 / 9180 H-Type = 140mm (5.51)

8474 / 9274 / 9280 H-Type = 140mm (5.51)

Dimension 'Y'

D-Type = 98.6mm (3.88)

H-Type = 106.4mm (4.19)

Ancillary Parts

EFR WASTEGATE CANISTER SELECTION GUIDE

Core Assy.	A-TYPE 0.64a/r TH	G-TYPE 0.80a/r TH	B-TYPE 0.83a/r TH	F & F(v)-TYPE 0.85a/r TH	C-TYPE 0.92a/r TH
6258	179282, 179283, or 179284	179420, 179421, or 179422	179285, 179286, or 179287	179282, 179283, or 179284	
6258*	Optional Super Short Canister 59001107255, 59001107262, or 59001107261				
6758					
6758*					
7163*					
7064					179285, 179286, or 179287
7670					
8374					
8474					
9274					
9180					
9280					

EFR WASTEGATE CANISTER BRACKET KIT SELECTION GUIDE

Core Assy.	A-TYPE 0.64a/r TH	G-TYPE 0.80a/r TH	B-TYPE 0.83a/r TH	F & F(v)-TYPE 0.85a/r TH	C-TYPE 0.92a/r TH	Each Wastegate Bracket Kit Includes:		
6258	179427	179428	179428	179427		(1) Stainless steel bracket		
6258*	Super Short Canister 59007119007					179428	Super Short Canister 59007119007	(3) Bracket to bearing housing screws
6758								(2) Canister to bracket lock nuts
6758*								(1) Actuator rod nut (outboard side)
7163*								(1) Long 410mm wastegate signal hose
7064				179428	(2) Hose clamps			
7670								
8374					179429			
8474								
9274								
9180								
9280								

EFR CANISTER PRELOAD GUIDE

ROD & SPRING FULL STROKE		LOW BOOST		MEDIUM BOOST		HIGH BOOST	
PRELOAD	CAPABILITY	179282, 179420, OR 179285 STANDARD CANISTER 59001107255 SUPER SHORT CANISTER		179283, 179421, OR 179286 STANDARD CANISTER 59001107262 SUPER SHORT CANISTER		179284, 179422, OR 179287 STANDARD CANISTER 59001107261 SUPER SHORT CANISTER	
(mm / nut turns)	inches (mm)	WG Crack-Open Pressure (psi)	Full Stroke Pressure (psi)	WG Crack-Open Pressure (psi)	Full Stroke Pressure (psi)	WG Crack-Open Pressure (psi)	Full Stroke Pressure (psi)
0	0.67" (17mm)	4.0 psi	13.7 psi	8.8 psi	20.6 psi	16.8 psi	32.3 psi
1	0.63" (16mm)	4.9 psi	13.8 psi	9.6 psi	20.6 psi	17.3 psi	32.3 psi
2	0.59" (15mm)	5.7 psi	14.0 psi	10.8 psi	20.6 psi	17.6 psi	32.3 psi
3	0.55" (14mm)	6.1 psi	14.1 psi	11.2 psi	20.6 psi	17.8 psi	32.3 psi
4	0.51" (13mm)	6.8 psi	14.3 psi	11.9 psi	20.6 psi	17.9 psi	32.3 psi
5	0.47" (12mm)	7.3 psi	14.4 psi	12.3 psi	20.6 psi	18.1 psi	32.3 psi
6	0.43" (11mm)	8.0 psi	14.4 psi	13.2 psi	20.6 psi	18.6 psi	32.3 psi
7	0.39" (10mm)	8.5 psi	14.6 psi	14.0 psi	20.6 psi	19.0 psi	32.3 psi
8	0.35" (9mm)	9.1 psi	14.6 psi	14.5 psi	20.6 psi	19.3 psi	32.3 psi
9	0.31" (8mm)	9.6 psi	14.7 psi	14.8 psi	20.6 psi	19.4 psi	32.3 psi
10	0.28" (7mm)	9.9 psi	14.7 psi	15.9 psi	20.6 psi	19.6 psi	32.3 psi
		Use with up to 13 psi applied pressure		Use with up to 19 psi applied pressure		Use with up to 31 psi applied pressure	

- Note 1: Avoid too little preload. The diaphragm can rub (and wear) against the top of the can. We recommend 3mm of preload as a starting point.
- Note 2: Avoid too much preload. Too much preload can cause premature diaphragm wear, but can be used functionally to limit travel and avoid boost droop at high RPM.
- Note 3: When using solenoid valve boost control, the signal pressure that the WG canister sees can be bled off. Select a canister that will allow nearly full stroke.
- Note 4: The "use with up to" pressures avoid long-term wear. By bottoming out the stroke, the diaphragm can be distressed over the course of time.
- Note 5: EFR turbo assemblies come standard with the "Medium Boost" WG canisters. "Low" or "High" as well as Super Short boost actuator canisters can be purchased from an EFR dealer.

Ancillary Parts

Hardware/Installation Kit

#179423

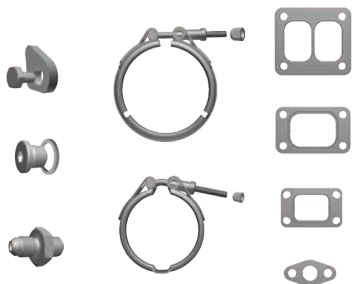

- (1) Turbine housing outlet V-band clamp
- (2) V-band clamp nuts
- (2) Water port plugs
- (6) Water port plug sealing washers
- (1) Oil inlet fitting (-4an) w/seal and washer
- (1) Compressor cover outlet V-band clamp for 83, 84, 91 & 92mm
- (5) Clamp plate bolts
- (5) Clamp plates, 1-hole
- (1) Turbine inlet gasket for T25 flange
- (1) Turbine inlet gasket for T3 flange
- (1) Turbine inlet gasket for T4 divided flange
- (2) Oil gasket

Clamp Kit, Turbine Housing to Bearing Housing for Aluminum B2 Bearing Housings

#59007119005



- (1) Clamp Plate, 3-hole
- (1) Clamp Plate, 2-hole
- (5) Bolts, Cross drilled A286
- (1) Shim

V-Band, Turbine Inlet for F(v) Housings

#59001095100



Super Short Canister

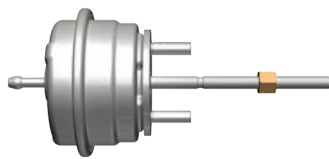

- | | | |
|-------------|--------------|-------------|
| 59001107255 | 59001107262 | 59001107261 |
| Low Boost | Medium Boost | High Boost |

Wastegate Bracket Kit for Super Short Canisters

#59007119007



- (1) Stainless steel bracket
- (2) Bracket to bearing housing screws
- (2) Canister to bracket lock nuts
- (1) Actuator rod nut (outboard side)
- (1) Long 410mm wastegate signal hose
- (2) Hose Clamps

Boost Control Solenoid Valve (BCSV) Kit

#179425



- (1) Boost control solenoid valve
- (2) BCSV screws
- (4) Hose clamps
- (1) Compressor cover boost port fitting
- (1) Comp cover boost port washer
- (1) Wastegate signal hose, 110mm
- (1) Wastegate signal hose, 410mm

Compressor Recirculation Valve Kit (CRV)

#179424

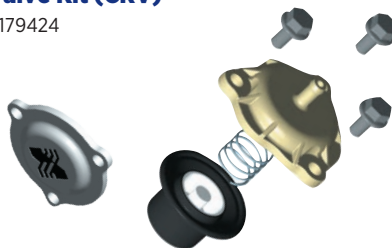

- (1) Plastic cover w/hose nipple
- (1) CRV disabling block-off plate
- (1) Diaphragm/piston assembly
- (1) Stiffer Spring #58061191364
- (3) Cover plate bolts w/locking compound

CRV Spring

Softer spring w/blue mark #58061191379

Standard / Stiffer Spring w/o mark #58061191364



Speed Sensor Kit

#179430

- (1) Speed sensor, frequency output
- (1) Speed sensor hold-down bolt



***Note: Speed Sensor signal conversion and display accessories can be purchased at: www.roadragegages.com

Wastegate Hose Kit

#179426

- (1) Wastegate signal hose, 410mm
- (2) Hose clamps



Turbo Speed Gauge (TSG-1)

The Turbo Speed Gauge (TSG-1) monitors turbo speed, and a whole lot more

- Plug and play solution for turbos outfitted with BorgWarner turbo speed sensors
- Includes open auxiliary channels for other devices such as MAP, Thermocouples, and Pressure Transducers
- Able to pass speed sensor and auxiliary channels through to data acquisition and/or engine ECU
- Graphically plots speed on a scrolling screen
- Converts speed to 0-5v signal
- Easily configurable for all BorgWarner turbocharger rotor groups

***Note: Available through select BorgWarner distributors



The passion of power



In 2002, the aftermarket group of BorgWarner Turbo Systems started a program named AirWerks. This independent aftermarket program was created to assist the needs of BorgWarner distributors who currently

Team: DNA Racing
Driver: Dennis Taylor
Vehicle: 1972 Chevy Nova SS
Racing Venue: Hot Rod Drag Week
Current Turbo of choice:
Twin S400SX-E 88mm



Team: Customs by Bigun
Driver: Eric Yost
Vehicle: 1968 Camaro
Racing Venue: Drag Week,
Extreme Street & Half Mile
Shootout / Horsepower Wars

Current Turbo of choice:
BorgWarner S500SX-E 94mm
partnered with **Work**
Turbocharger



Photo courtesy of Wes Taylor with Lock It In Productions

sell into the market of competitive motorsports. The program also can assist those customers who are looking to increase the performance of their factory turbocharged car or retrofit a naturally aspirated engine.

Driver: Glen Hunter
Vehicle: 1956 Chevrolet Bel Air
Racing Venue: Hot Rod Drag Week

Current Turbo of choice:
Twin S400SX-E 88mm



S1BG

120 - 320 HP Turbo



TURBO FRAME DIMENSIONS

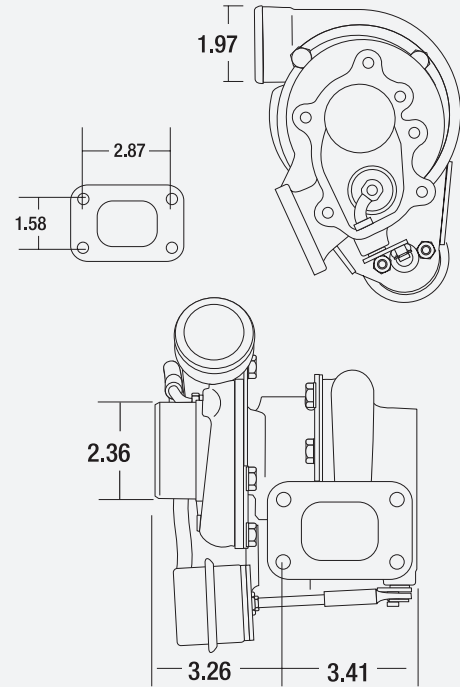

FEATURES

- Twin hydrodynamic journal bearings
- Integrated wastegate assembly
- Adjustable compressor and turbine housing orientation

Turbo Part #	Comp. Wheel O.D. (in)	Comp Wheel O.D. (mm)	Comp Wheel Inducer Dia. (in)	Comp Wheel Inducer Dia. (mm)	Turbine Wheel O.D. (in)	Turbine Wheel O.D. (mm)	Turbine Wheel Exducer (in)	Turbine Wheel Exducer (mm)	Turbine Housing A/R	Cartridge Assembly	Service Kit
313295	1.90	48.31	1.35	34.21	1.85	46.99	1.58	40.00	0.35	N/A	318374
313296	2.08	52.91	1.55	39.32	2.08	52.92	1.80	45.73	0.46	315358	318374
313683	2.08	52.91	1.55	39.32	2.08	52.92	1.80	45.73	0.61	N/A	318374
313297	2.28	57.96	1.70	43.28	2.08	52.92	1.80	45.73	0.61	313737	318374
313798	2.28	57.96	1.70	43.28	2.08	52.92	1.80	45.73	0.81	313737	318374

COMPRESSOR MAP / APPLICABLE TO PART NUMBER 313296

Comp. Wheel Inducer Dia. (mm) 39.32
Comp. Wheel Outer Dia. (mm) 52.91

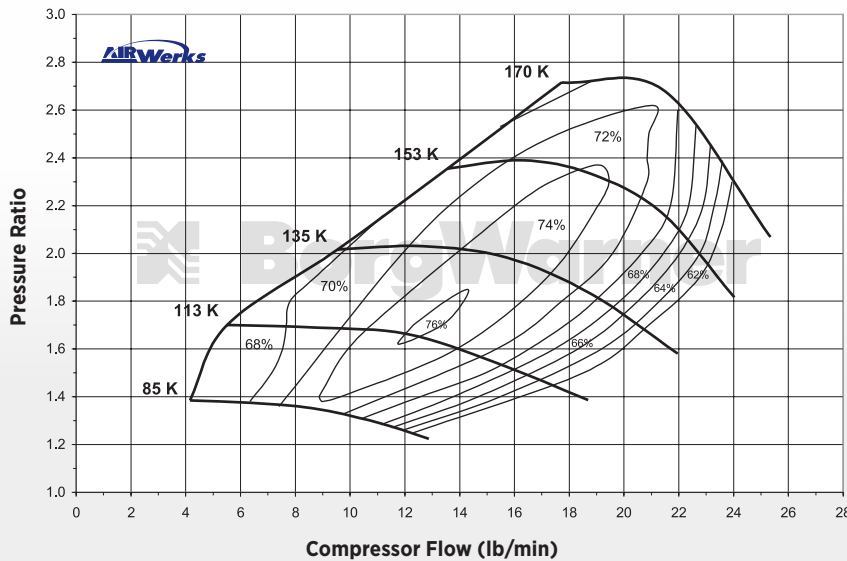

S200SX

220 - 580 HP Turbo



FEATURES

- Twin hydrodynamic journal bearings
- Extended tip technology compressor wheel
- Twin scroll turbine housing
- Adjustable compressor and turbine housing orientation



TURBO FRAME DIMENSIONS

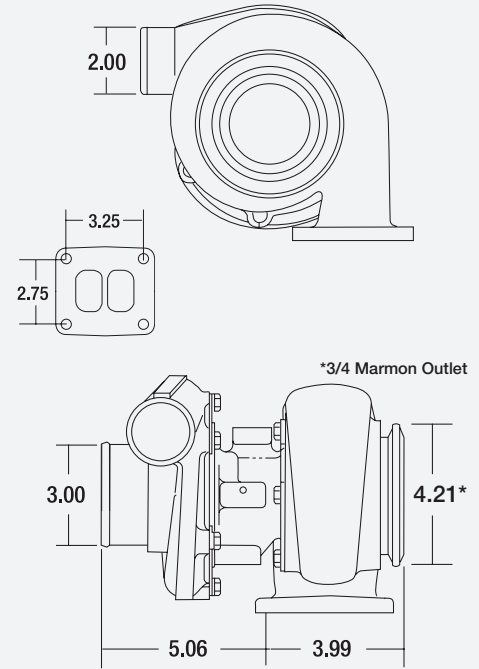

Turbo Part #	Comp. Wheel O.D. (in)	Comp Wheel O.D. (mm)	Comp Wheel Inducer Dia. (in)	Comp Wheel Inducer Dia. (mm)	Turbine Wheel O.D. (in)	Turbine Wheel O.D. (mm)	Turbine Wheel Exducer (in)	Turbine Wheel Exducer Dia (mm)	Turbine Housing A/R	Turbine Inlet	Cartridge Assembly	Service Kit
177258	2.74	69.57	1.81	45.90	2.74	69.56	2.42	61.43	0.83	VTF	176639	318383
177267	2.74	69.57	1.95	49.56	2.74	69.56	2.42	61.43	1.09	VTF	176642	318383
177257	2.74	69.57	2.00	50.72	2.74	69.56	2.42	61.43	0.83	VTF	176638	318383
177268	3.00	76.20	2.20	55.80	2.74	69.56	2.42	61.43	1.22	VTF	176637	318383
178034*	3.00	76.20	2.20	55.80	2.74	69.56	2.42	61.43	1.22	VTF	N/A	318383
178042*	3.00	76.20	2.20	55.80	2.74	69.56	2.42	61.43	1.27	VTF	N/A	318383

* Compressor inlet diameter 4.00"

COMPRESSOR MAP / APPLICABLE TO PART NUMBER 177268

Comp. Wheel Inducer Dia. (mm) 55.80
Comp. Wheel Outer Dia. (mm) 76.20

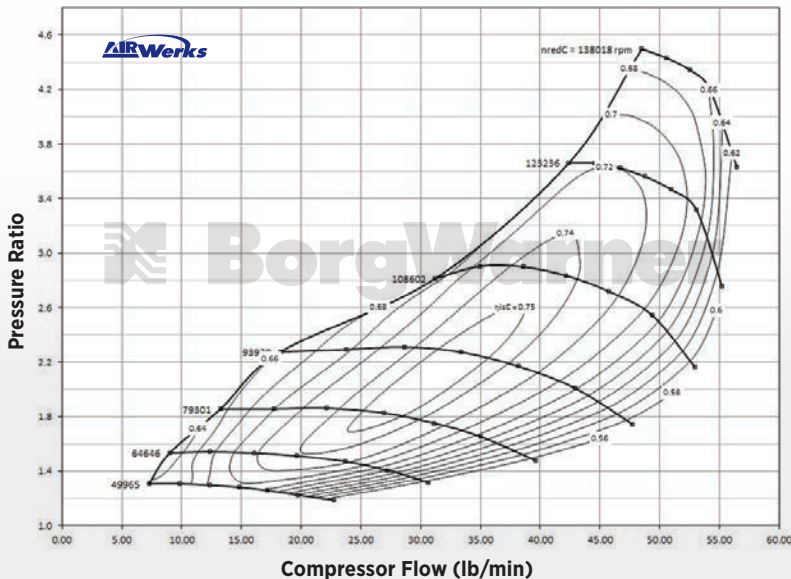

TURBINE HOUSING

Part #	A/R	Inlet Configuration	Notes
177191	0.83	Volute, Twin Flow	T4 Bolt Pattern T3 Volute Opening 70mm Turbine Wheel
177193	1.00		
177196	1.09		
177192	1.15		
177194	1.22		
178331	1.27		

S200SX-E

300 - 650 HP Super-Core



FEATURES

- Integrated speed sensor port
- Forged milled compressor wheel
- Pre-machined boost port
- Optimized compressor stage aerodynamics



Not included with turbo assemblies: Speed sensor, Turbine outlet V-Band, Drain port fitting

SUPER-CORE FRAME DIMENSIONS

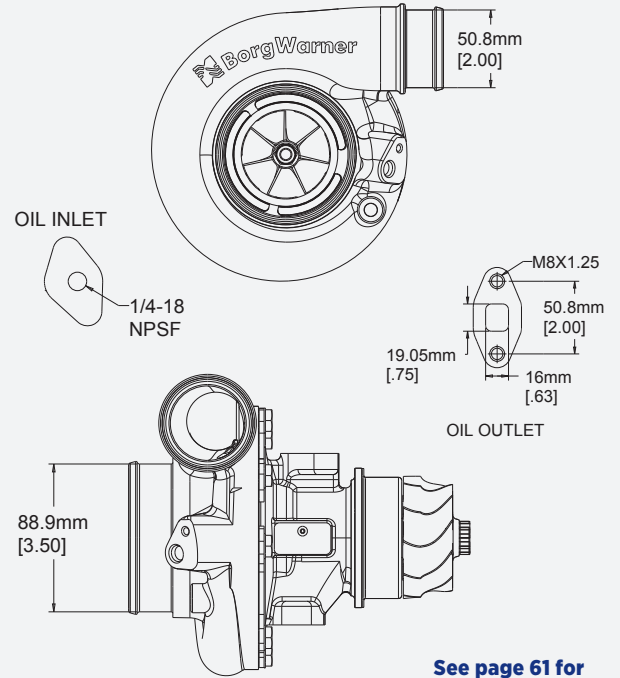

See page 61 for speed sensor details

Super-Core Part #	Comp. Wheel O.D. (in)	Comp. Wheel O.D. (mm)	Comp Wheel Inducer Dia. (in)	Comp Wheel Inducer Dia. (mm)	Turbine Wheel O.D. (in)	Turbine Wheel O.D. (mm)	Turbine Wheel Exducer (in)	Turbine Wheel Exducer (mm)	Service Kit
12709095019	2.74	69.60	2.05	52.17	2.74	69.56	2.42	61.43	318383
12769095003	3.00	76.20	2.25	57.15	2.74	69.56	2.42	61.43	318383

TURBINE HOUSING

Part #	A/R	Inlet Configuration	Notes
177191	0.83	Volute, Twin Flow T3 Volute Opening	70mm Turbine Wheel
177193	1.00		
177196	1.09		
177192	1.15		
177194	1.22		
178331	1.27		

All turbine housing mounting hardware, clamp plates and cap screws are included with Super-Core.

COMPRESSOR MAP / APPLICABLE TO PART NUMBER 313296

S200SX-E 300 - 550 HP Super-Core Part #: 12709095019

Comp. Wheel Inducer Dia. (mm) 52.17
Comp. Wheel Outer Dia. (mm) 69.60

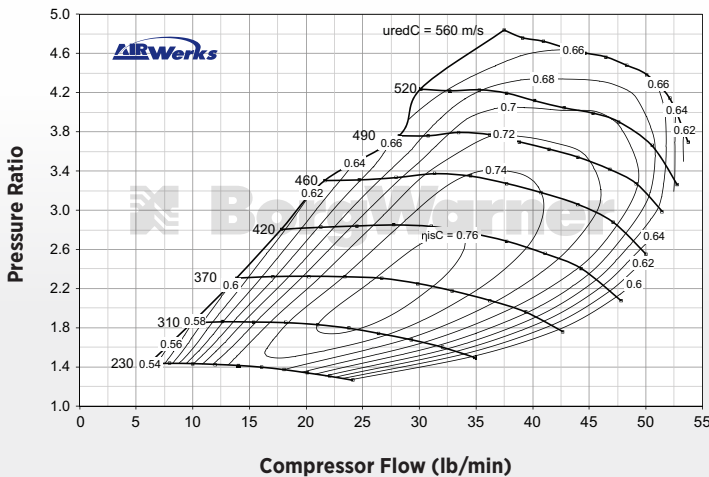

S200SX-E 300 - 650 HP Super-Core Part #: 12769095003

Comp. Wheel Inducer Dia. (mm) 57.15
Comp. Wheel Outer Dia. (mm) 76.20

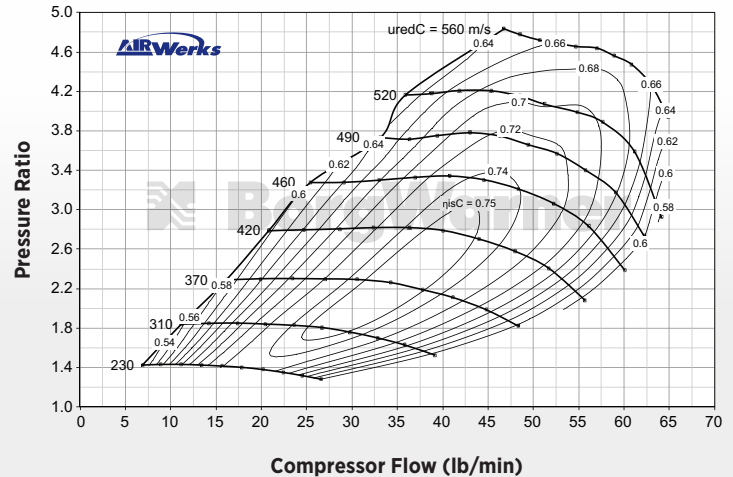

S300SX3

320 - 800 HP Turbo



FEATURES

- Twin hydrodynamic journal bearings
- Extended tip technology compressor wheel
- Twin scroll turbine housing options available
- Adjustable compressor and turbine housing orientation
- Compressor cover recirculation grooves



TURBO FRAME DIMENSIONS

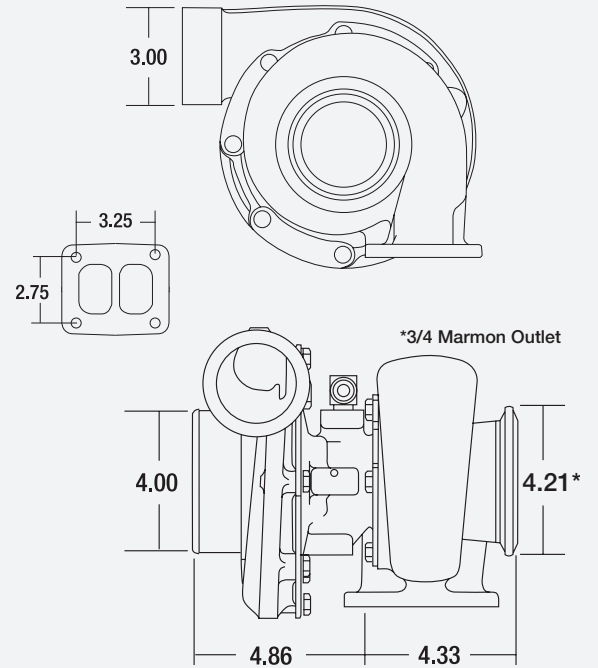

Turbo Part #	Comp. Wheel O.D. (in)	Comp Wheel O.D. (mm)	Comp Wheel Inducer Dia.	Comp Wheel Inducer Dia. (mm)	Turbine Wheel O.D. (in)	Turbine Wheel O.D. (mm)	Turbine Wheel Exducer (in)	Turbine Wheel Exducer (mm)	Turbine Housing A/R	Cartridge Assembly	Service Kit (Standard)	Service Kit (360° thrust bearing)
177281	3.60	91.44	2.60	66.11	3.14	79.76	2.89	73.37	0.88	176634	318393	13007110005
177275	3.60	91.44	2.60	66.11	3.14	79.76	2.89	73.37	0.91	176646	318393	13007110005
177272	3.29	83.47	2.36	60.03	3.00	76.20	2.66	67.56	0.91	176635	318393	13007110005

COMPRESSOR MAP / APPLICABLE TO PART NUMBER 177281 & 177275

Comp. Wheel Inducer Dia. (mm) 66.11
Comp. Wheel Outer Dia. (mm) 91.44

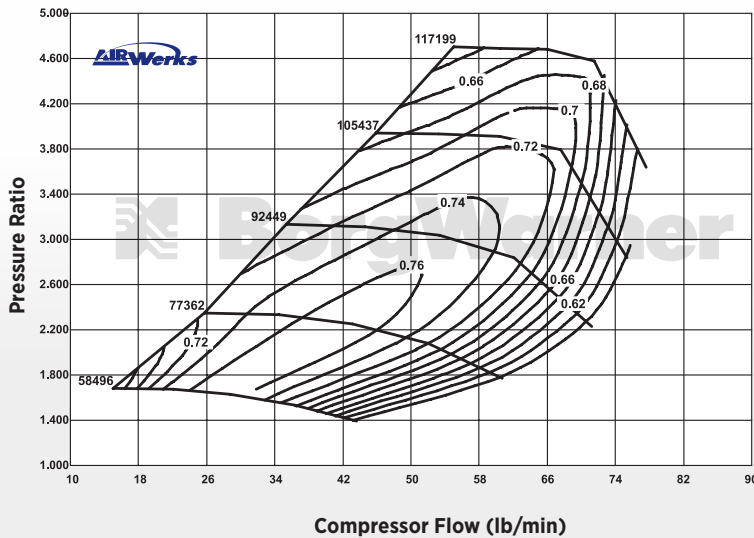

TURBINE HOUSING

Part #	A/R	Inlet Configuration	Notes
177211	0.88	Volute, Open Flow	80mm Turbine Wheel
177208	0.91	Volute, Twin Flow	
179905	1.00	Volute, Twin Flow	
177210	0.88	Volute, Open Flow	76mm Turbine Wheel
177207	0.91	Volute, Twin Flow	
177209	1.00	Volute, Twin Flow	

S300SX3

320 - 800 HP Turbo



FEATURES

- Twin hydrodynamic journal bearings
- Extended tip technology compressor wheel
- Twin scroll turbine housing options available
- Adjustable compressor and turbine housing orientation
- Compressor cover recirculation grooves



TURBO FRAME DIMENSIONS

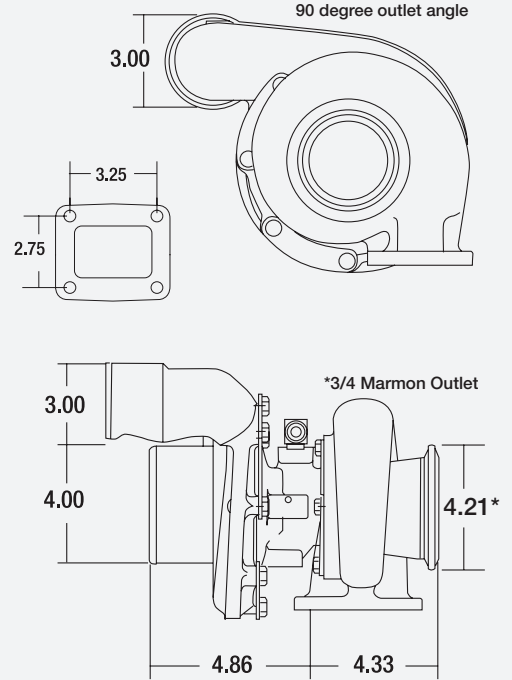

Turbo Part #	Comp. Wheel O.D. (in)	Comp Wheel O.D. (mm)	Comp Wheel Inducer Dia. (in)	Comp Wheel Inducer Dia. (mm)	Turbine Wheel O.D. (in)	Turbine Wheel O.D. (mm)	Turbine Wheel Exducer (in)	Turbine Wheel Exducer (mm)	Turbine Housing A/R	Cartridge Assembly	Service Kit (Standard)	Service Kit (360° thrust bearing)
177280	3.29	83.47	2.36	60.03	3.00	76.20	2.66	67.56	0.88	171901	318393	13007110005
177283	3.44	87.37	2.48	62.99	3.00	76.20	2.66	67.56	0.88	176648	318393	13007110005
177284	3.60	91.44	2.60	66.11	3.14	79.76	2.89	73.37	0.91	176650	318393	13007110005

COMPRESSOR MAP / APPLICABLE TO PART NUMBER 177283

Comp. Wheel Inducer Dia. (mm) 62.99
Comp. Wheel Outer Dia. (mm) 87.37

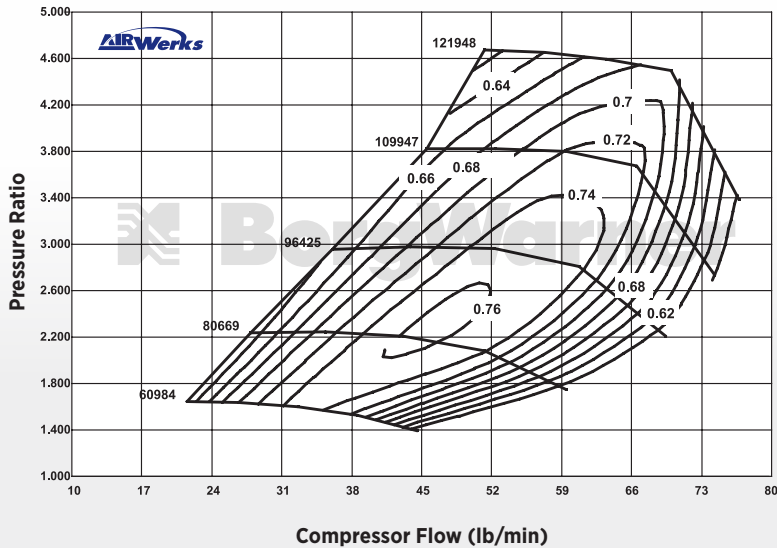

TURBINE HOUSING

Part #	A/R	Inlet Configuration	Notes
177211	0.88	Volute, Open Flow	T4 Inlet 80mm Turbine Wheel
177208	0.91	Volute, Twin Flow	
179905	1.00	Volute, Twin Flow	
177210	0.88	Volute, Open Flow	T4 Inlet 76mm Turbine Wheel
177207	0.91	Volute, Twin Flow	
177209	1.00	Volute, Twin Flow	

S300GX

Cummins 5.9 Upgrade

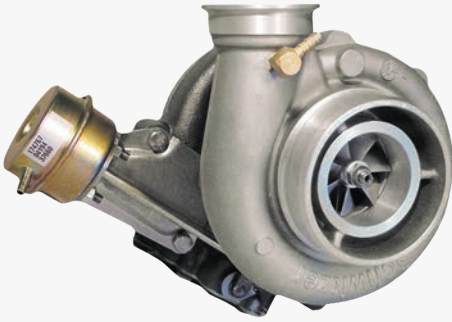

**BorgWarner
S300G Upgrade
Turbo for
Cummins 5.9
Engines**

FEATURES

The BorgWarner S300GX replacement turbo is more than a great match for your Cummins 5.9 engine. The S300G is aerodynamically designed to provide boost that can propel your Cummins 5.9 engine to 400 wheel horsepower. A rugged thrust bearing system helps insure the durability of your S300G, even under these extreme load conditions.

To realize the full horsepower potential of your S300G, we highly recommend the use of the following upgrade components:

- 4" Exhaust System
- High Flow Air Filter
- Performance Chip
- Ram Air Intake Tube
- High Flow Fuel Injectors
- Boost Control Fitting

Turbo Part #	Comp Wheel O.D. (in)	Comp Wheel O.D. (mm)	Comp Wheel Inducer Dia. (in)	Comp Wheel Inducer Dia. (mm)	Turbine wheel O.D. (in)	Turbine wheel O.D. (mm)	Turbine wheel exducer (in)	Turbine wheel exducer (mm)	Turbine housing A/R	Super Core	Service Kit	Service Kit (360° thrust bearing)
174430	3.29	83.47	2.25	57.10	2.92	74.17	2.54	64.52	0.80	NA	318393	13007110005
13749880014	3.00	76.20	2.25	57.15	2.92	74.17	2.54	64.52	0.80	13009097059	318393	13007110005

COMPRESSOR MAP / APPLICABLE TO PART NUMBER 13749880014

Comp. Wheel Inducer Dia. (mm) 57.15
Comp. Wheel Outer Dia. (mm) 76.20

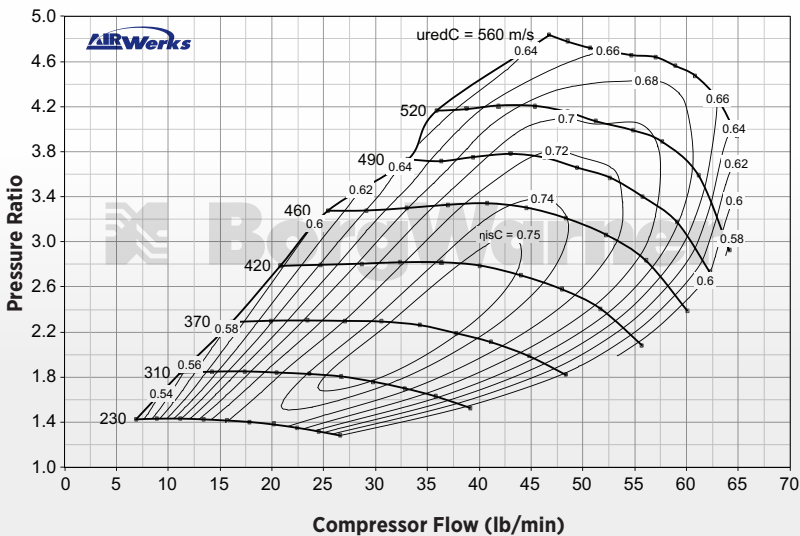

TURBO FRAME DIMENSIONS

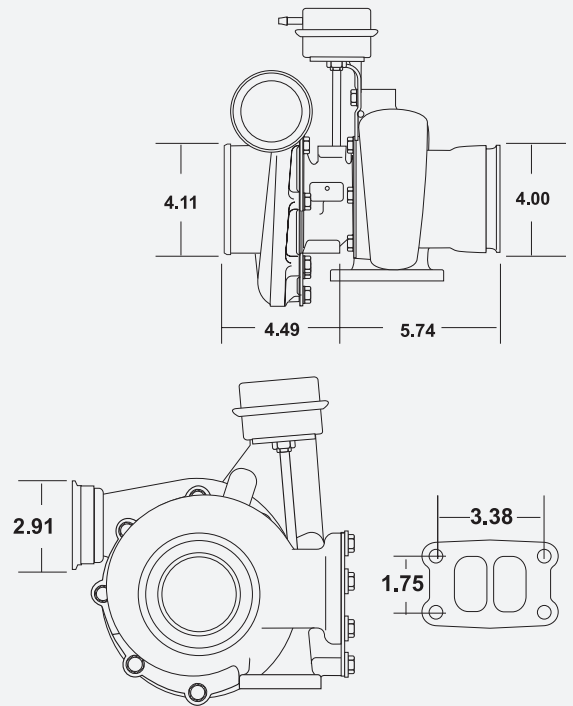

S300SX-E

400-1100 HP Super-Core



FEATURES

- 360 degree thrust bearing
- Integrated speed sensor port
- Forged milled compressor wheel
- Flexible compressor cover outlet options
- Pre-machined boost port
- Optimized compressor stage aerodynamics

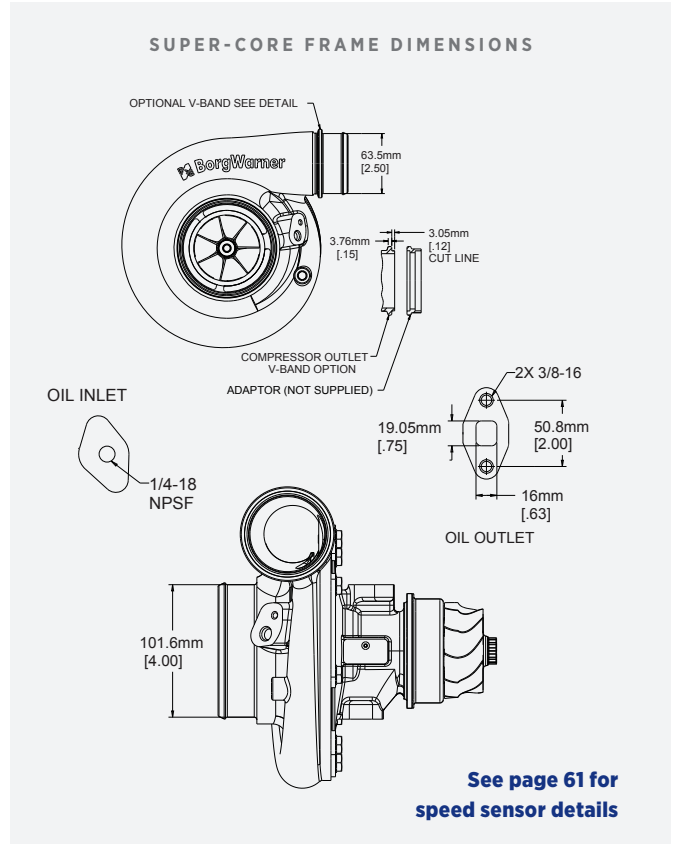

See page 61 for speed sensor details

Not included with turbo assemblies: Speed sensor, Turbine outlet V-Band, Drain port fitting

Super-Core Part #	Comp. Wheel O.D. (in)	Comp. Wheel O.D. (mm)	Comp Wheel Inducer Dia. (in)	Comp Wheel Inducer Dia. (mm)	Turbine Wheel O.D. (in)	Turbine Wheel O.D. (mm)	Turbine Wheel Exducer (in)	Turbine Wheel Exducer (mm)	Service Kit (360° thrust bearing)
13009097056	3.29	83.47	2.42	61.44	3.00	76.20	2.66	67.56	13007110005
13009097053	3.29	83.47	2.42	61.44	3.14	79.76	2.89	73.37	13007110005
13009097006	3.44	87.37	2.48	62.99	3.00	76.20	2.66	67.56	13007110005
13009097047	3.44	87.37	2.48	62.99	3.14	79.76	2.89	73.37	13007110005
13009097008	3.44	87.37	2.54	64.47	3.00	76.20	2.66	67.56	13007110005
13009097055	3.44	87.37	2.54	64.47	3.14	79.76	2.89	73.37	13007110005
13009097049	3.60	91.44	2.60	66.11	3.14	79.76	2.89	73.37	13007110005
13009097051	3.60	91.44	2.72	69.00	3.14	79.76	2.89	73.37	13007110005
NEW! 72mm 13009095091	3.58	91.00	2.83	72.00	3.14	79.76	2.89	73.37	13007110005

All turbine housing mounting hardware, clamp plates and cap screws included with Super-Core.

TURBINE HOUSING

Part #	A/R	Inlet Configuration	Notes
177211	0.88	Volute, Open Flow	T4 Inlet 80mm Turbine Wheel
177208	0.91	Volute, Twin Flow	
179905	1.00	Volute, Twin Flow	
177210	0.88	Volute, Open Flow	76mm Turbine Wheel
177207	0.91	Volute, Twin Flow	
177209	1.00	Volute, Twin Flow	



S300SX-E 400 - 775 HP Part #: 13009097053, 13009097056

Comp. Wheel Inducer Dia. (mm) 61.44
Comp. Wheel Outer Dia. (mm) 83.47

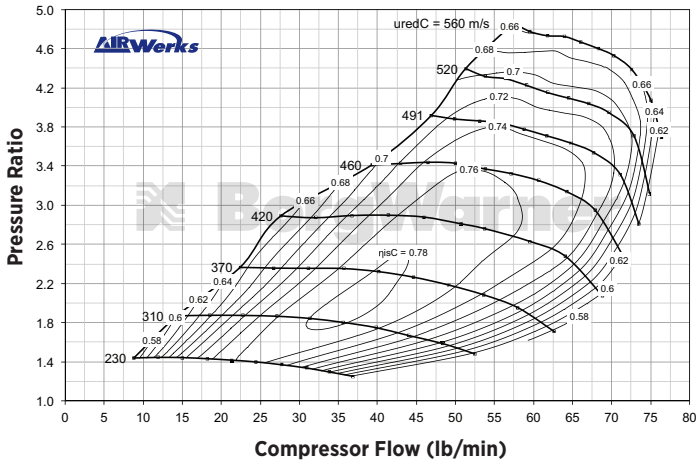

S300SX-E 500 - 875 HP Part #: 13009097049

Comp. Wheel Inducer Dia. (mm) 66.11
Comp. Wheel Outer Dia. (mm) 91.44

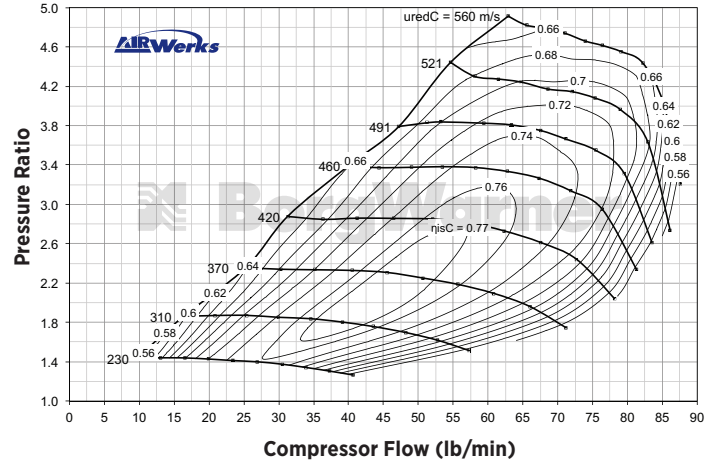

S300SX-E 450 - 785 HP Part #: 13009097006, 13009097047

Comp. Wheel Inducer Dia. (mm) 62.99
Comp. Wheel Outer Dia. (mm) 87.37

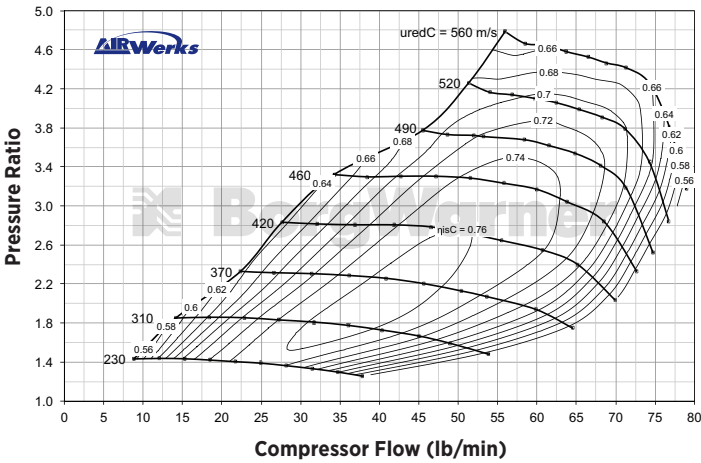

S300SX-E 500 - 1000 HP Part #: 13009097051

Comp. Wheel Inducer Dia. (mm) 69.00
Comp. Wheel Outer Dia. (mm) 91.44

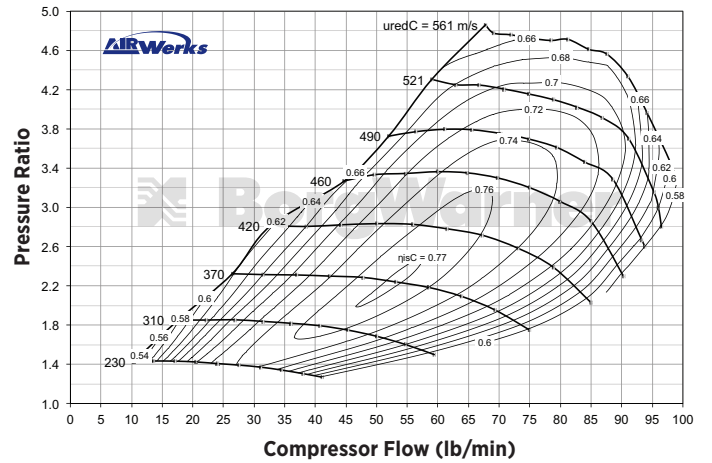

S300SX-E 450 - 825 HP Part #: 13009097008, 13009097055

Comp. Wheel Inducer Dia. (mm) 64.47
Comp. Wheel Outer Dia. (mm) 87.37

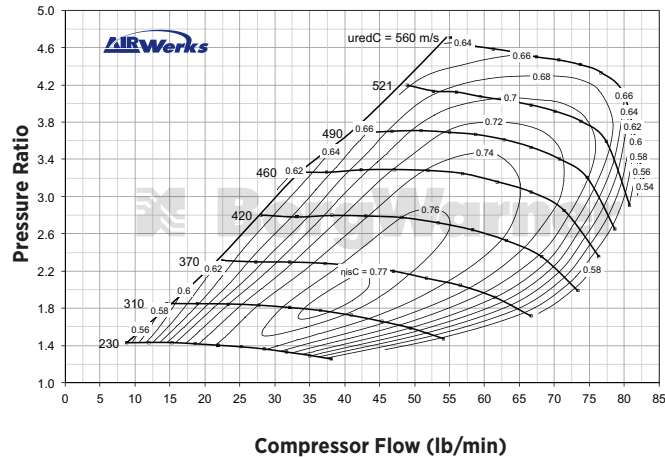

S300SX-E 500 - 1100 HP Part #: 13009095091

Comp. Wheel Inducer Dia. (mm) 72.00
Comp. Wheel Outer Dia. (mm) 91.00

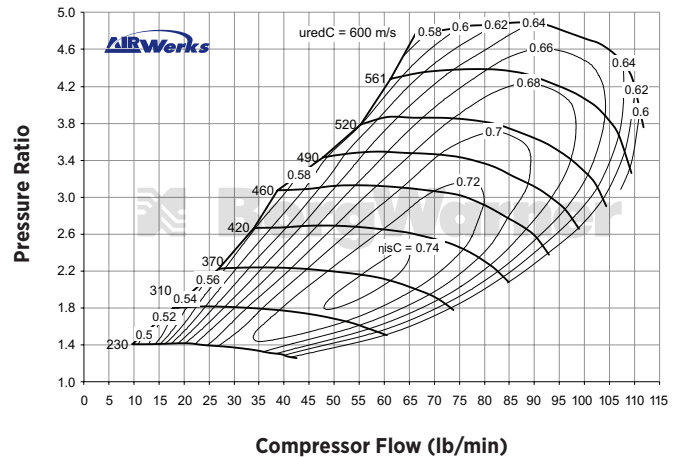

S400SX

400 - 1300 HP Turbo



FEATURES

- Twin hydrodynamic journal bearings
- Extended Tip Technology Compressor Wheel
- Twin Scroll Turbine Housing
- Adjustable compressor and turbine housing orientation
- Standard turbine inlet and outlet connections
- Compressor cover recirculation grooves



TURBO FRAME DIMENSIONS

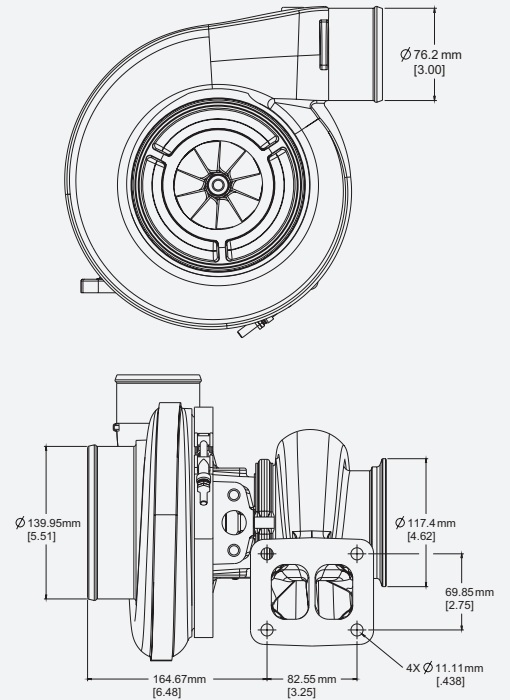

Turbo Part #	Comp. Wheel O.D. (in)	Comp Wheel O.D. (mm)	Comp Wheel Inducer Dia. (in)	Comp Wheel Inducer Dia. (mm)	Turbine Wheel O.D. (in)	Turbine Wheel O.D. (mm)	Turbine Wheel Exducer (in)	Turbine Wheel Exducer (mm)	Turbine A/R	Super-Core	Cartridge Assembly	Service Kit (Standard)	Service Kit (360° thrust bearing)
178855	3.60	91.44	2.66	67.66	3.29	83.47	2.92	74.29	1.10	179352	178856	318396	14007110000
14879880082	3.78	96.00	2.83	72.00	3.44	87.37	3.22	81.74	1.10	14009097006	14009097007	318396	14007110000
*179174	3.94	100.17	2.94	74.56					1.10	*179175	*14009097001	318396	14007110000
*179176	4.13	104.84	2.99	76.00					1.10	*178781	*178782	318396	14007110000
179180	4.32	109.73	3.16	80.30					1.25	179179	179181	318396	14007110000
179182	4.32	109.73	3.24	82.20					1.25	179184	179183	318396	14007110000

* Cast compressor wheel



Team: Turbo4 Racing

Driver: Tony Niemczyk

Vehicle: Dragster

Racing Venue: NHRA Lucas Oil Series

Current Turbo of choice:
S400SX-E 76mm

TURBINE HOUSING

Part #	A/R	Inlet Configuration		Notes
177102	0.90	Volute, Twin Flow	T4 Inlet	83mm Turbine Wheel
177103	1.00			
177104	1.10			
177105	1.25			
178787	0.90	Volute, Twin Flow	T4 Inlet	87mm Turbine Wheel
178788	1.00			
178789	1.10			
178790	1.25			

S400SX 400 - 900 HP Part #: 178855

Comp. Wheel Inducer Dia. (mm) 67.66
Comp. Wheel Outer Dia. (mm) 91.44

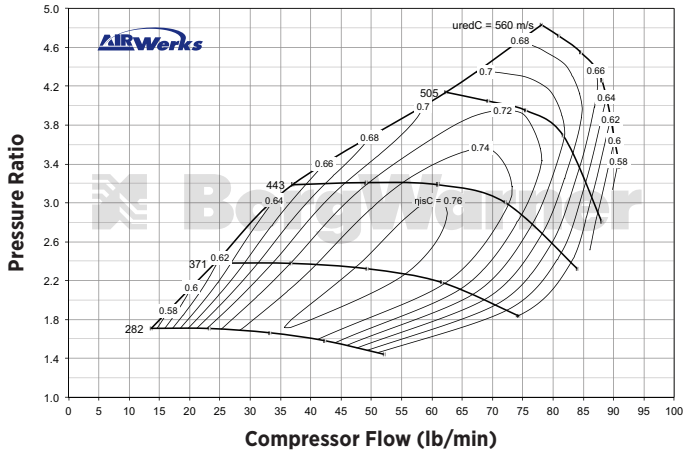

S400SX 550 - 1100 HP Part #: 179176

Comp. Wheel Inducer Dia. (mm) 76.00
Comp. Wheel Outer Dia. (mm) 104.84

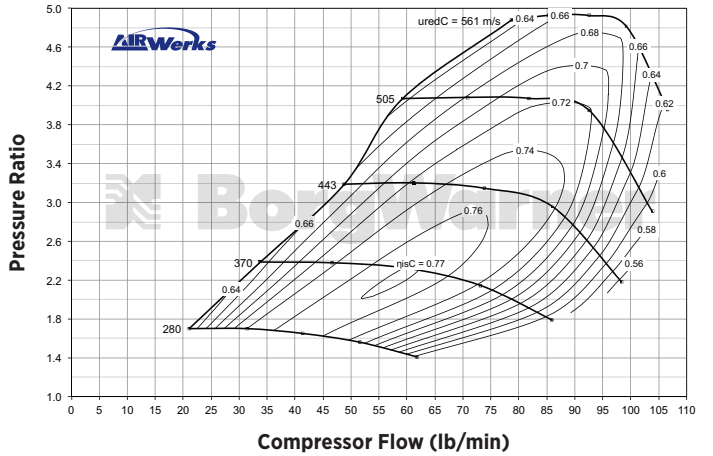

S400SX-E 500 - 1100 HP Part #: 14879880082

Comp. Wheel Inducer Dia. (mm) 72.00
Comp. Wheel Outer Dia. (mm) 96.00

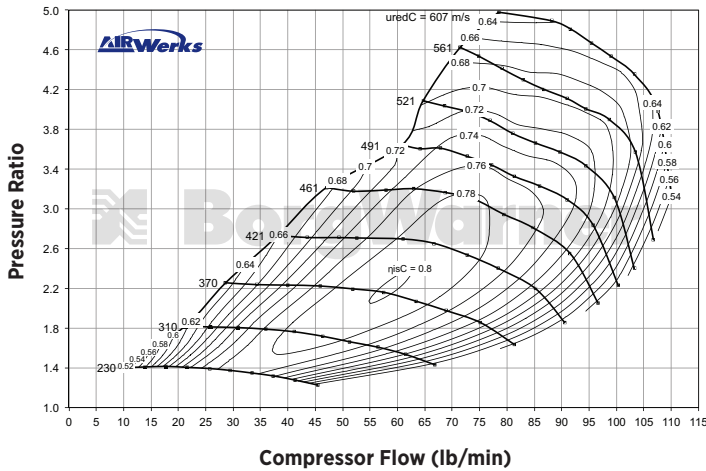

S400SX 750 - 1250 HP Part #: 179180

Comp. Wheel Inducer Dia. (mm) 80.30
Comp. Wheel Outer Dia. (mm) 109.73

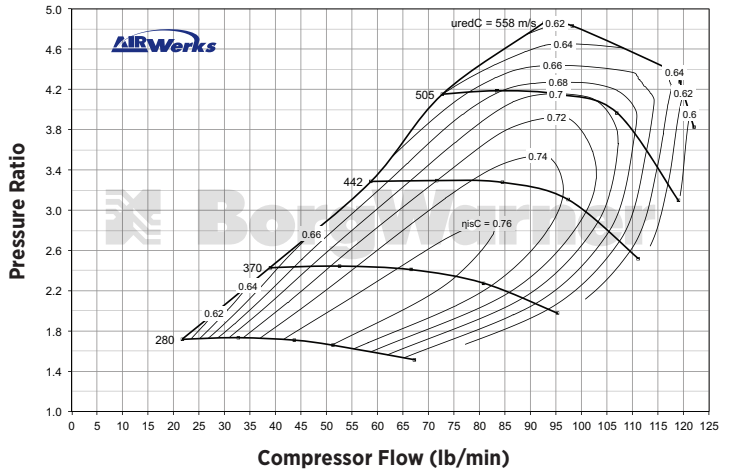

S400SX 500 - 1050 HP Part #: 179174

Comp. Wheel Inducer Dia. (mm) 74.56
Comp. Wheel Outer Dia. (mm) 100.17

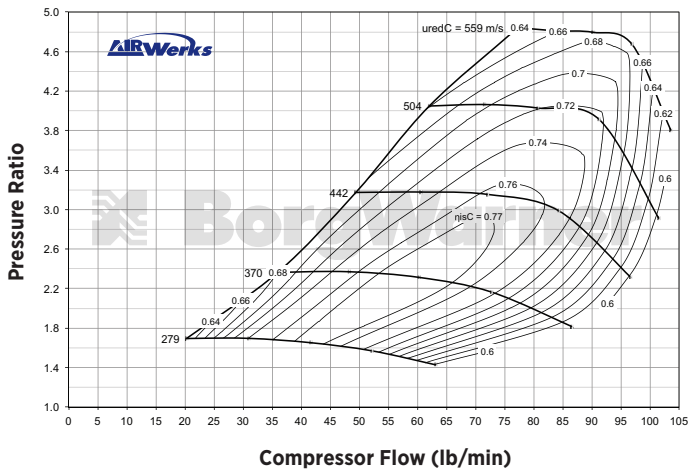

S400SX 750 - 1300 HP Part #: 179182

Comp. Wheel Inducer Dia. (mm) 82.20
Comp. Wheel Outer Dia. (mm) 109.73

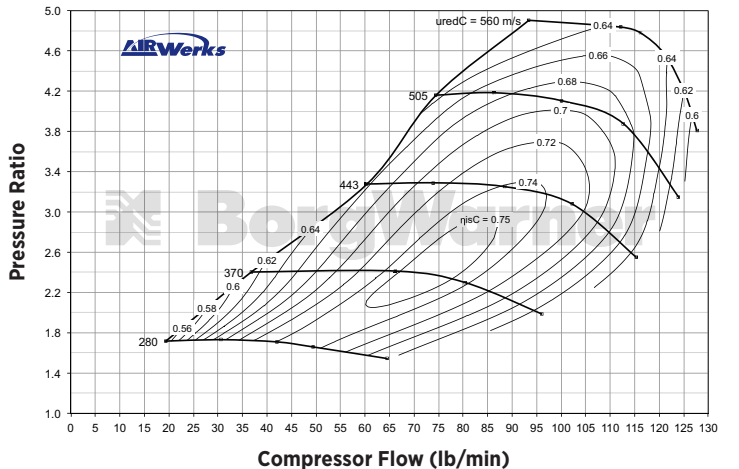

S400SX-E

500 - 1200 HP Turbo



FEATURES

- Twin hydrodynamic journal bearings
- Extended Tip Technology Compressor Wheel
- Twin Scroll Turbine Housing
- Adjustable compressor and turbine housing orientation
- Standard turbine inlet and outlet connections
- Compressor cover recirculation grooves



SUPER-CORE FRAME DIMENSIONS

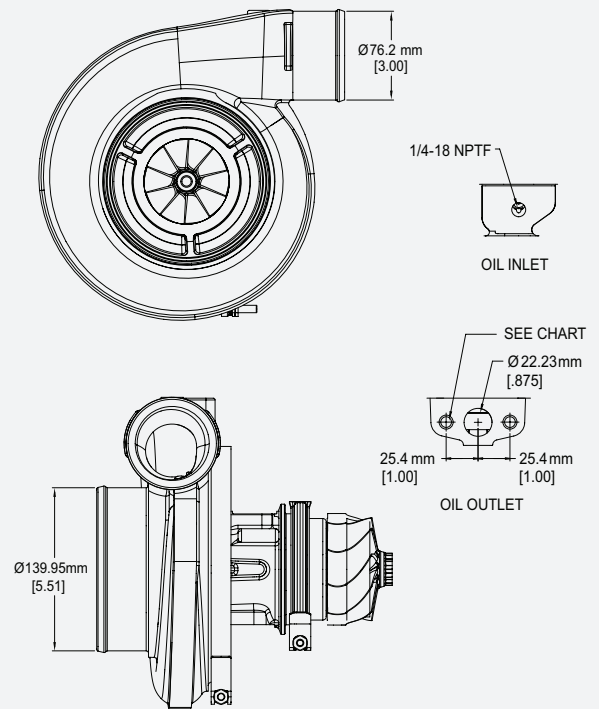

Super-Core	Comp. Wheel O.D. (in)	Comp Wheel O.D. (mm)	Comp Wheel Inducer Dia. (in)	Comp Wheel Inducer Dia. (mm)	Turbine Wheel O.D. (in)	Turbine Wheel O.D. (mm)	Turbine Wheel Exducer (in)	Turbine Wheel Exducer (mm)	Oil outlet thread	Service Kit (360° thrust bearing)
14009097006	3.78	96.00	2.83	72.00	3.44	87.37	3.22	81.74	M8 X 1.25	14007110000
14009097014	3.94	100.00	2.99	76.00	3.44	87.37	3.22	81.74	M10 X 1.5	14007110000

TURBINE HOUSING

Part #	A/R	Inlet Configuration	Notes
178787	0.90	Volute, Twin Flow	87mm Turbine Wheel
178788	1.00		
178789	1.10		
178790	1.25		

COMPRESSOR MAPS

S400SX-E 500 - 1100 HP Part #'s: 14009097006

Comp. Wheel Inducer Dia. (mm) 72.00
Comp. Wheel Outer Dia. (mm) 96.00

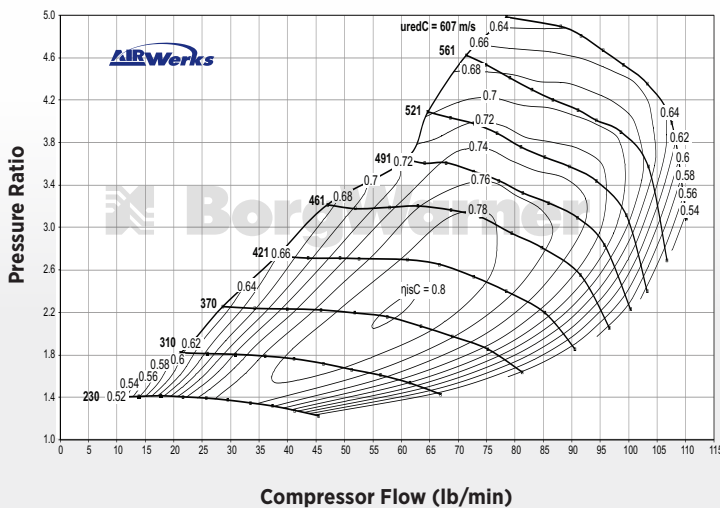

S400SX-E 550 - 1200 HP Part #'s: 14009097013 & 14009097014

Comp. Wheel Inducer Dia. (mm) 76.00
Comp. Wheel Outer Dia. (mm) 100.00

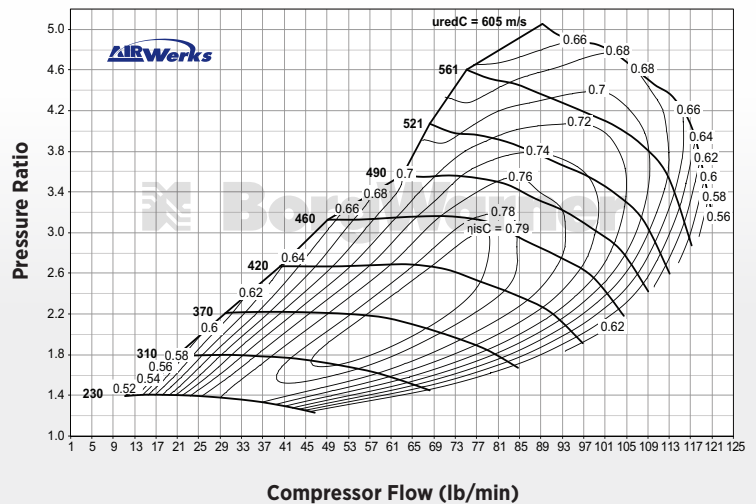

S400SX-E

650 - 1575 HP Turbo



FEATURES

- Twin hydrodynamic journal bearings
- Extended Tip Technology Compressor Wheel
- Twin Scroll Turbine Housing
- Adjustable compressor and turbine housing orientation
- Standard turbine inlet and outlet connections
- Compressor cover recirculation grooves
- Speed sensor
- V-band or hose bead

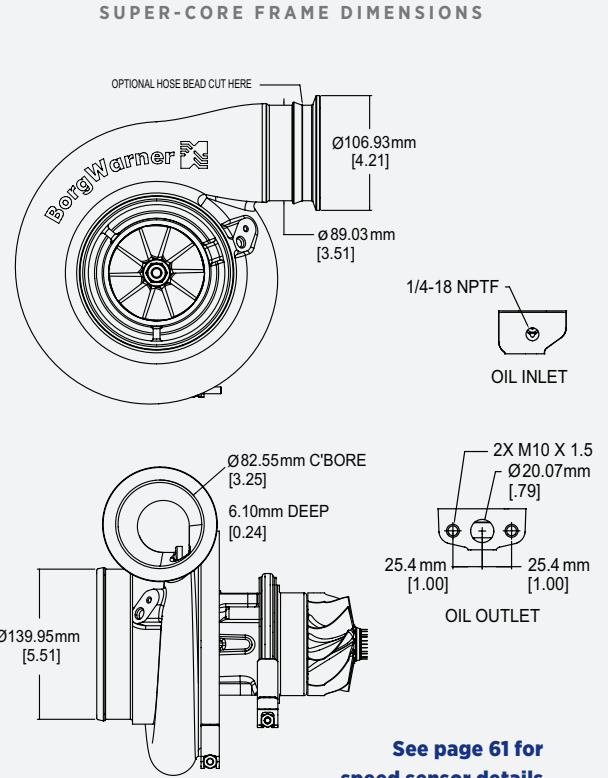

Super-Core	Comp. Wheel O.D. (in)	Comp Wheel O.D. (mm)	Comp Wheel Inducer Dia. (in)	Comp Wheel Inducer Dia. (mm)	Turbine Wheel O.D. (in)	Turbine Wheel O.D. (mm)	Turbine Wheel Exducer (in)	Turbine Wheel Exducer (mm)	Service Kit (360° thrust bearing)
*14009097013	3.94	100.00	2.99	76.00	3.77	95.70	3.47	88.05	14007110003
14009097010	4.33	110.00	3.16	80.30	3.77	95.70	3.47	88.05	14007110003
14009097008	4.33	110.00	3.46	87.93	3.77	95.70	3.47	88.05	14007110003

*See page 46 for compressor map

TURBINE HOUSING

Part #	A/R	Inlet Configuration	Notes
14961019007	1.15	Volute, Twin Flow	96mm Turbine Wheel
171698	1.32		
14961016101	1.45		
14961016100	1.58		

COMPRESSOR MAPS

S400SX-E 650 - 1350 HP Part #: 14009097010

Comp. Wheel Inducer Dia. (mm) 80.30
Comp. Wheel Outer Dia. (mm) 110.00

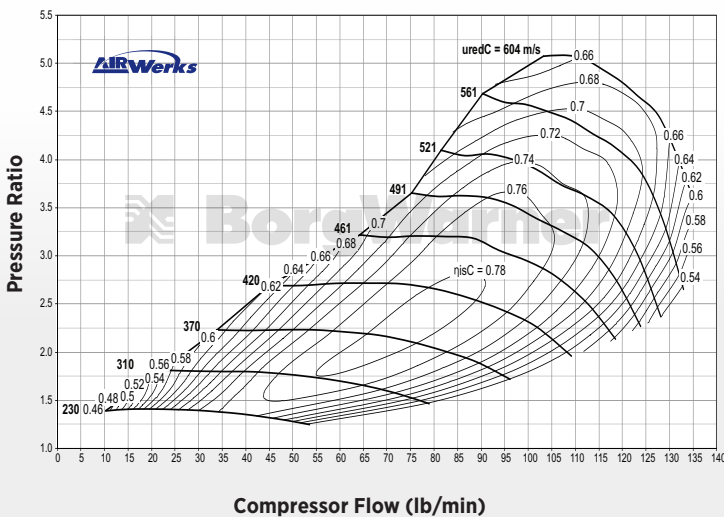

S400SX-E 750 - 1575 HP Part #: 14009097008

Comp. Wheel Inducer Dia. (mm) 87.93
Comp. Wheel Outer Dia. (mm) 110.00

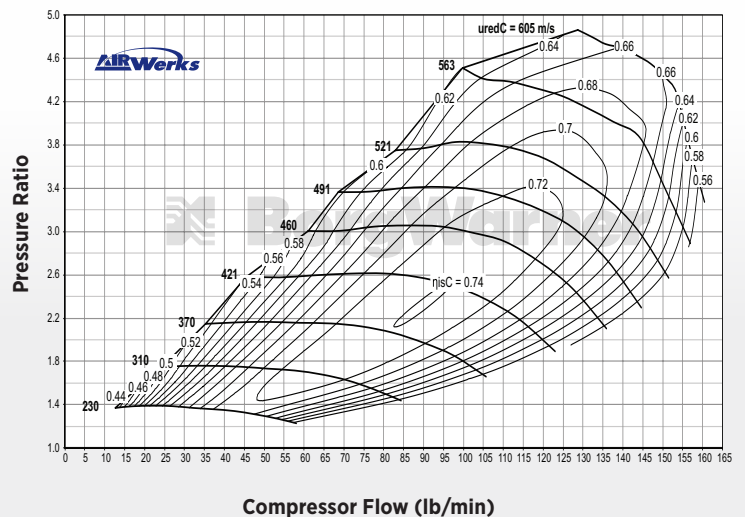

S400SX3

500 - 1050 HP Turbo



FEATURES

- Twin hydrodynamic journal bearings
- Extended tip technology compressor wheel
- Twin scroll turbine housing
- Adjustable compressor and turbine housing orientation
- Standard turbine inlet and outlet allows for drop-in to existing turbocharged applications
- Compressor cover recirculation grooves
- V-band discharge



TURBO FRAME DIMENSIONS

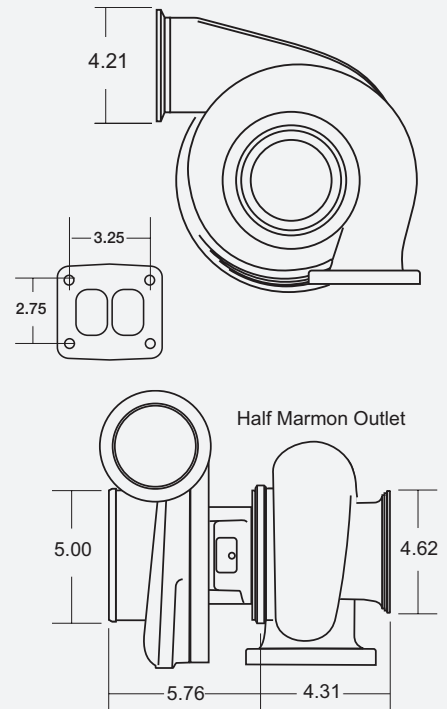

Turbo Part #	Comp. Wheel O.D. (in)	Comp Wheel O.D. (mm)	Comp Wheel Inducer Dia. (in)	Comp Wheel Inducer Dia. (mm)	Turbine Wheel O.D. (in)	Turbine Wheel O.D. (mm)	Turbine Wheel Exducer (in)	Turbine Wheel Exducer (mm)	Turbine Housing A/R	Cartridge Assembly	Service Kit (Standard)	Service Kit (360° thrust bearing)
177248	3.94	100.17	2.80	71.08	3.29	83.47	2.92	74.29	1.10	177249	318396	14007110000
177101	3.94	100.17	2.94	74.56	3.29	83.47	2.92	74.29	1.10	176807	318396	14007110000

COMPRESSOR MAP / APPLICABLE TO PART NUMBER 177101

Comp. Wheel Inducer Dia. (mm) 74.56
Comp. Wheel Outer Dia. (mm) 100.17

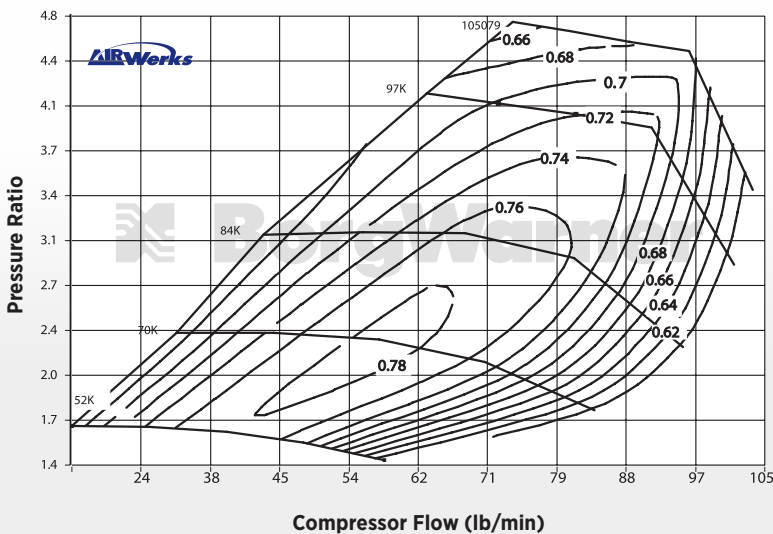

TURBINE HOUSING

Part #	A/R	Inlet Configuration		Notes
177102	0.90	Volute, Twin Flow	T4 Inlet	83mm Turbine Wheel
177103	1.00			
177104	1.10			
177105	1.25			

S400SX4

500 - 1050 HP Turbo

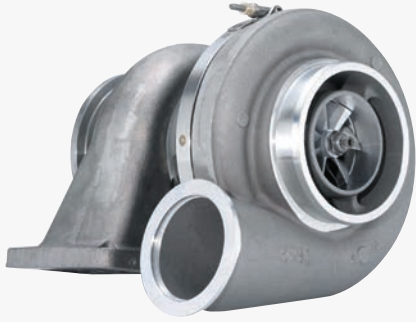

FEATURES

- Twin hydrodynamic journal bearings
- Extended tip technology compressor wheel
- Twin scroll turbine housing
- Adjustable compressor and turbine housing orientation
- Compressor cover recirculation grooves
- V-band discharge



TURBO FRAME DIMENSIONS

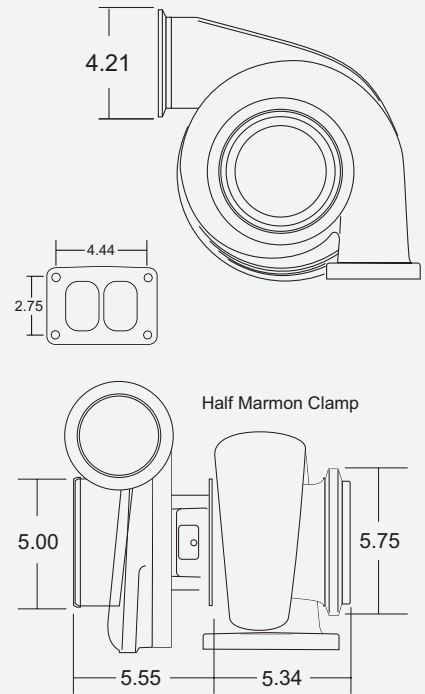

Turbo Part #	Comp. Wheel O.D. (in)	Comp Wheel O.D. (mm)	Comp Wheel Inducer Dia. (in)	Comp Wheel Inducer Dia. (mm)	Turbine Wheel O.D. (in)	Turbine Wheel O.D. (mm)	Turbine Wheel Exducer (in)	Turbine Wheel Exducer (mm)	Turbine Housing A/R	Cartridge Assembly	Service Kit (Standard)	Service Kit (360° thrust bearing)
171701	3.94	100.17	2.80	71.08	3.77	95.70	3.47	88.05	1.32	171699	176391	14007110003
171702	3.94	100.17	2.94	74.56	3.77	95.70	3.47	88.05	1.32	171703	176391	14007110003
176806	3.94	100.17	2.94	74.56	3.29	83.47	2.92	74.29	1.10	176807	318396	14007110000

COMPRESSOR MAP / APPLICABLE TO PART NUMBER 171702 AND 176806

Comp. Wheel Inducer Dia. (mm) 74.56
Comp. Wheel Outer Dia. (mm) 100.17

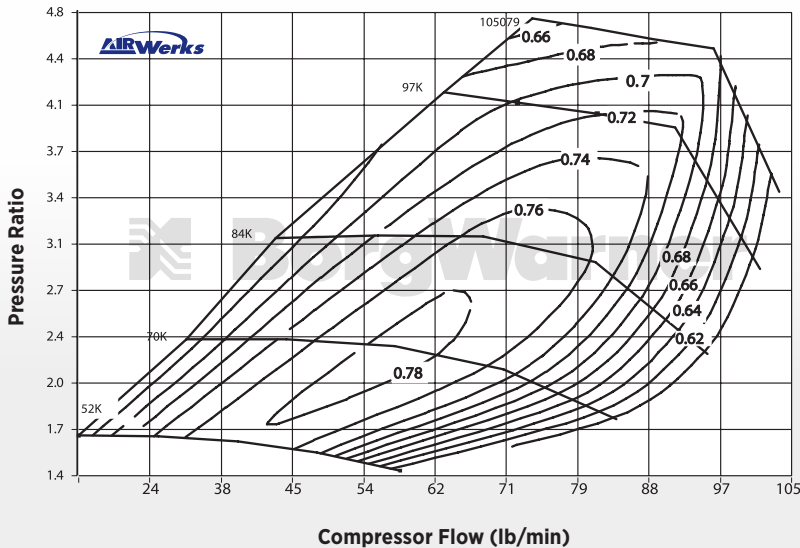

TURBINE HOUSING FOR 176806 ONLY

Part #	A/R	Inlet Configuration	Notes
176809	0.90	Volute, Twin Flow T6 Inlet	83mm Turbine Wheel
176810	1.00		
176811	1.10		
176812	1.25		

TURBINE HOUSING FOR 171701 AND 171702

Part #	A/R	Inlet Configuration	Notes
14961019007	1.15	Volute, Twin Flow T6 Inlet	96mm Turbine Wheel
171698	1.32		
14961016101	1.45		
14961016100	1.58		

S400SX4

750 - 1250 HP Turbo



FEATURES

- Twin hydrodynamic journal bearings
- Extended tip technology compressor wheel
- Twin scroll turbine housing
- Adjustable compressor and turbine housing orientation
- Compressor cover recirculation grooves



TURBO FRAME DIMENSIONS

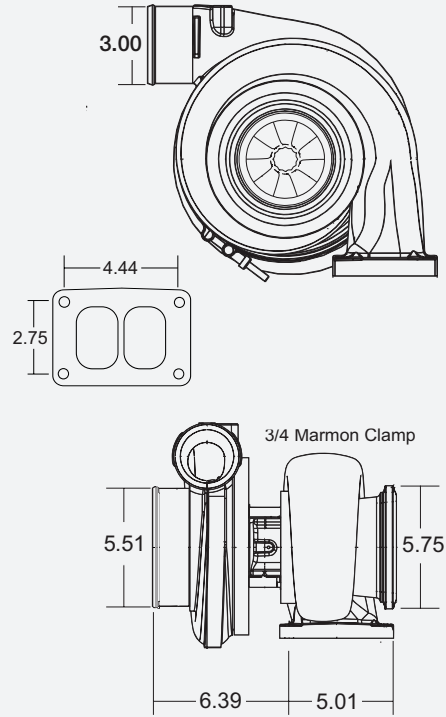

Turbo Part #	Comp. Wheel O.D. (in)	Comp Wheel O.D. (mm)	Comp Wheel Inducer Dia. (in)	Comp Wheel Inducer Dia. (mm)	Turbine Wheel O.D. (in)	Turbine Wheel O.D. (mm)	Turbine Wheel Exducer (in)	Turbine Wheel Exducer (mm)	Turbine Housing A/R	Cartridge Assembly	Service Kit (Standard)	Service Kit (360° thrust bearing)
177287	4.32	109.73	3.16	80.30	3.77	95.70	3.47	88.05	1.32	176654	176391	14007110003

COMPRESSOR MAP

Comp. Wheel Inducer Dia. (mm) 80.30
Comp. Wheel Outer Dia. (mm) 109.73

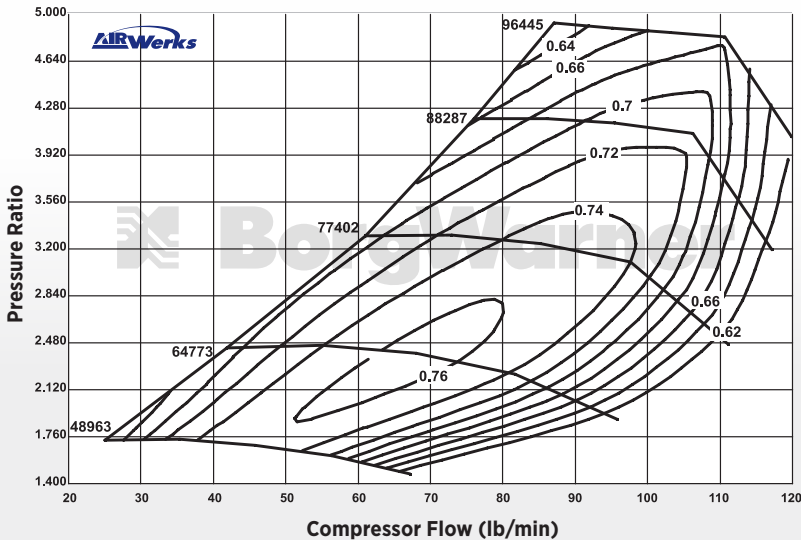

TURBINE HOUSING

Part #	A/R	Inlet Configuration	Notes
14961019007	1.15	Volute, Twin Flow T6 Inlet	96mm Turbine Wheel
171698	1.32		
14961016101	1.45		
14961016100	1.58		

S500SX

900 - 1475 HP Turbo



S500SX

900 - 1575 HP Turbo

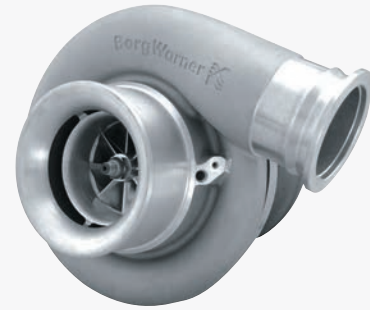

- Twin hydrodynamic journal bearings
- Extended Tip Technology Compressor Wheel
- Available in twin scroll and open flow turbine volute options
- Adjustable compressor and turbine housing orientation

- Compressor cover recirculation grooves
- Optimized compressor inlet geometry
- Dual machined compressor cover discharge connection (v-band or hose bead)
- Premachined speed sensor mounting boss



Turbo Part #	Comp. Wheel O.D. (in)	Comp. Wheel O.D. (mm)	Comp Wheel Inducer Dia. (in)	Comp Wheel Inducer Dia. (mm)	Turbine Wheel O.D. (in)	Turbine Wheel O.D. (mm)	Turbine Wheel Exducer (in)	Turbine Wheel Exducer (mm)	Turbine Housing A/R	Super-Core	Cartridge Assembly	Service Kit (360° thrust bearing)
179188	4.73	120.20	3.47	88.19	4.32	109.73	3.90	99.08	0.85	179186*	179187	173611
179191	4.73	120.20	3.57	90.67	4.32	109.73	3.90	99.08	0.85	179190*	179189	173611

* Super-Core options found on page 56

See page 61 for speed sensor installation details

COMPRESSOR MAPS

S500SX 900 - 1475 HP Turbo Part #: 179188

Comp. Wheel Inducer Dia. (mm) 88.19
Comp. Wheel Outer Dia. (mm) 120.20

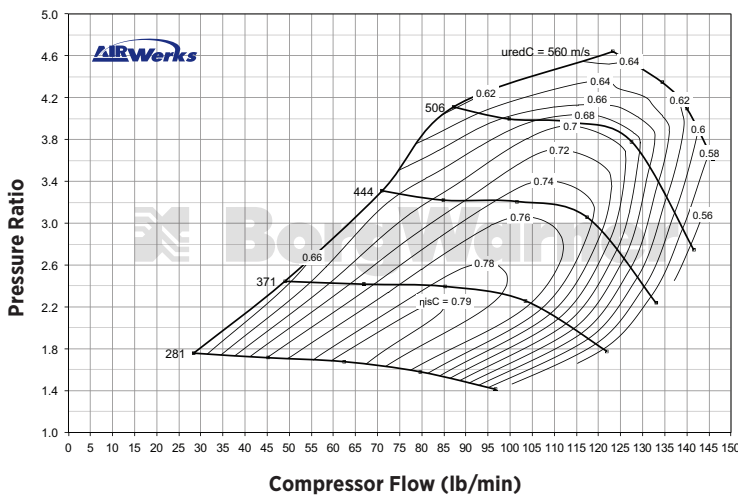

S500SX 900 - 1575 HP Turbo Part #: 179191

Comp. Wheel Inducer Dia. (mm) 90.67
Comp. Wheel Outer Dia. (mm) 120.20

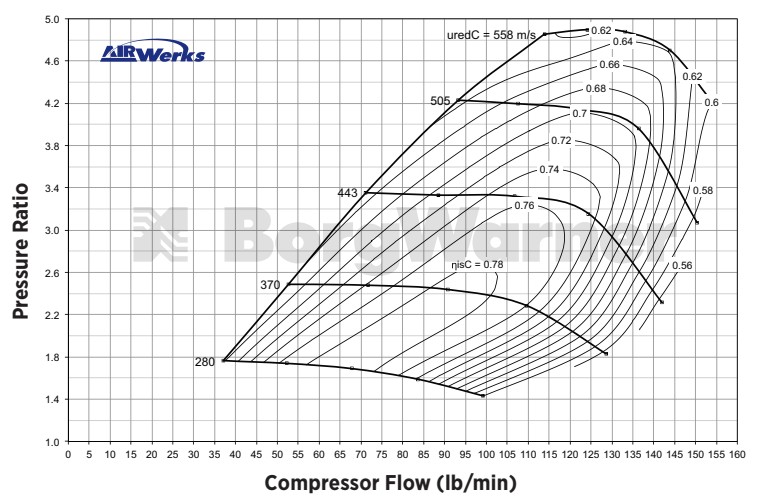

S500SX

TURBO FRAME DIMENSIONS

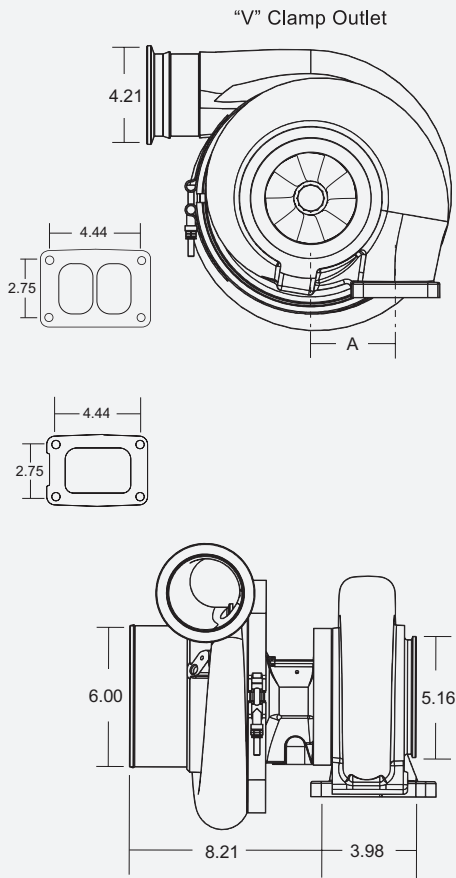

S500SX Super-Core

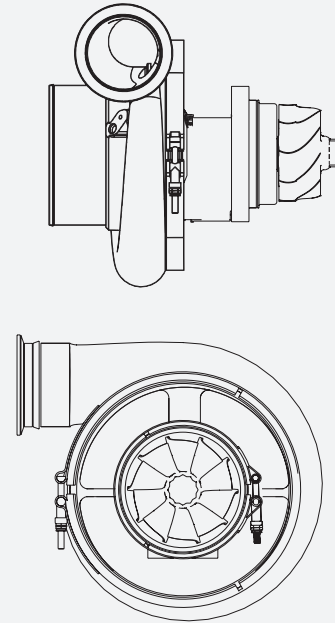

T6

TURBO FRAME DIMENSIONS

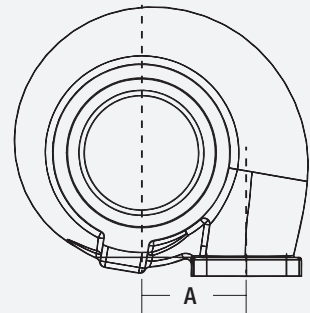
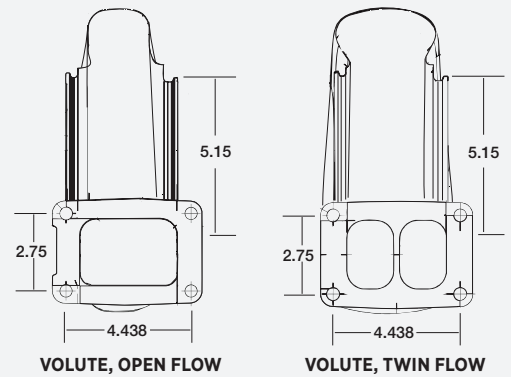

TURBINE HOUSING

Part #	A/R	Turbine Inlet Centerline (A)	Other Notes
179159	0.85	3.62"	Volute, Open Flow
179160	1.00	3.62"	Volute, Open Flow
179161	1.15	4.25"	Volute, Open Flow
178498	1.30	3.62"	Volute, Open Flow; .50" Longer Turbine Discharge
179162	1.45	4.25"	Volute, Open Flow
179478	1.15	3.62"	Volute, Twin Flow (Divided)
179192	1.45	3.62"	Volute, Twin Flow (Divided)
179193	1.60	3.62"	Volute, Twin Flow (Divided)

110MM (O.D.) TURBINE WHEEL

Component	Part #	Part #
Turbo	179188	179191
Super-Core	179186	179190

S500SX-E

900 - 1875 HP Turbo

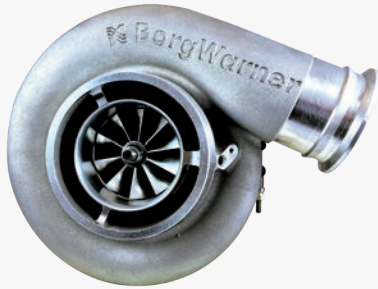

FEATURES

- Twin hydrodynamic journal bearings
- Extended Tip Technology Compressor Wheel
- Twin Scroll Turbine Housing
- Adjustable compressor and turbine housing orientation
- Standard turbine inlet and outlet connections
- Compressor cover recirculation grooves
- Speed sensor
- V-band or hose bead



TURBO FRAME DIMENSIONS

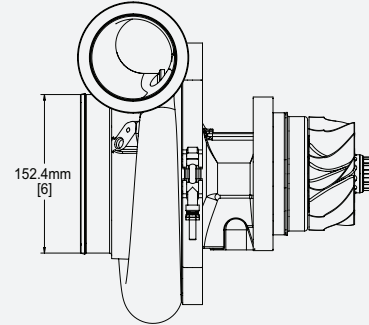
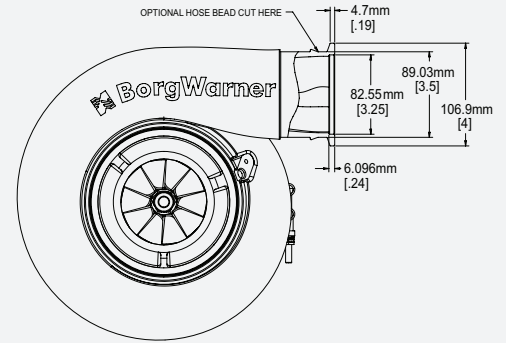

Super- Core	Comp. Wheel O.D. (in)	Comp Wheel O.D. (mm)	Comp Wheel Inducer Dia. (in)	Comp Wheel Inducer Dia. (mm)	Turbine Wheel O.D. (in)	Turbine Wheel O.D. (mm)	Turbine Wheel Ex-ducer	Turbine Wheel Exducer (mm)	Service Kit (360° thrust bearing)
15009097001	4.72	120.00	3.46	87.93	4.32	109.73	3.90	99.08	173611
15009097002	4.72	120.00	3.69	93.80	4.32	109.73	3.90	99.08	173611

TURBINE HOUSING

*See page 56

See page 61 for speed sensor installation details

Part #	A/R	Inlet Configuration	Turbine Inlet to Centerline*	Notes
179159	0.85	Volute, Open Flow	3.62"	110 Turbine Wheel
179160	1.00	Volute, Open Flow	3.62"	
179161	1.15	Volute, Open Flow	4.25"	
178498	1.30	Volute, Open Flow (.50" longer discharge)	3.62"	
179162	1.45	Volute, Open Flow	4.25"	
179478	1.15	Volute, Twin Flow	3.62"	
179192	1.45	Volute, Twin Flow	3.62"	
179193	1.60	Volute, Twin Flow	3.62"	

COMPRESSOR MAPS

S500SX-E 900 - 1650 HP Part #: 15009097001

Comp. Wheel Inducer Dia. (mm) 87.93
Comp. Wheel Outer Dia. (mm) 120.00

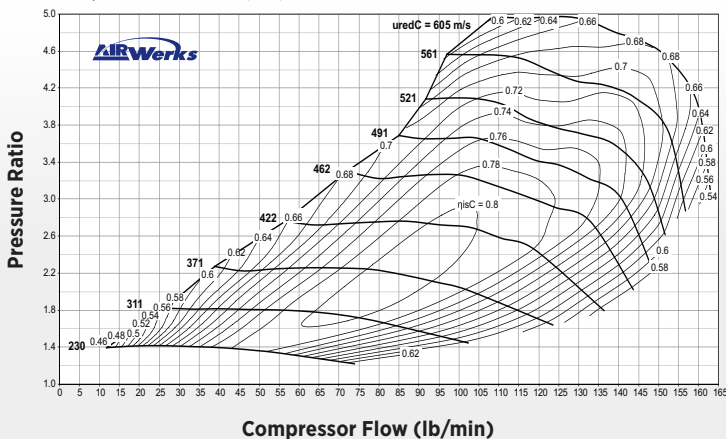

S500SX-E 900 - 1875 HP Part #: 15009097002

Comp. Wheel Inducer Dia. (mm) 93.80
Comp. Wheel Outer Dia. (mm) 120.00

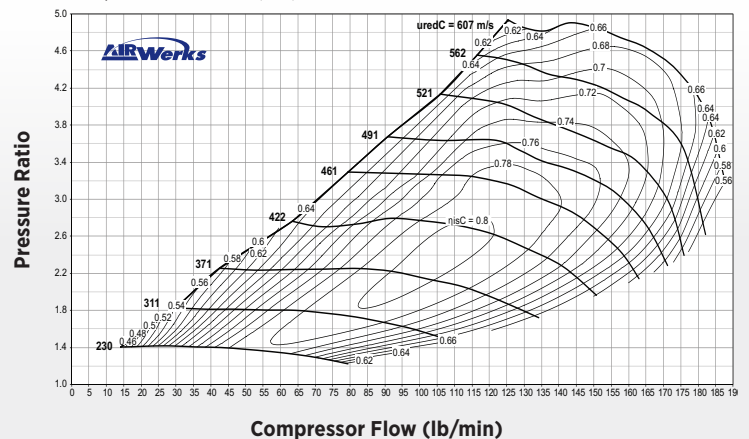

S410SX

600-900 (HP Turbo-15L Diesel)

TURBO FRAME DIMENSIONS

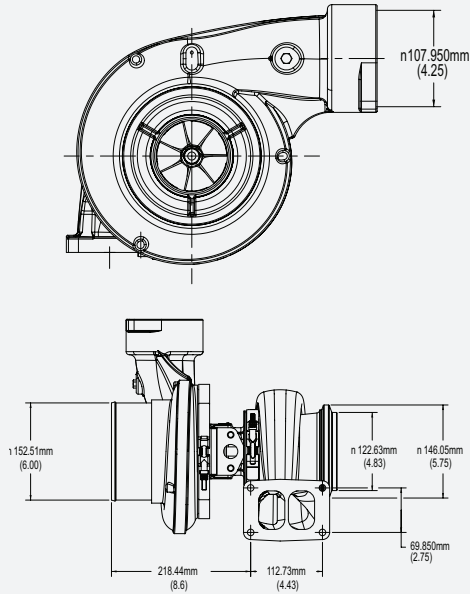

S410SX

600-750 (HP Turbo-15L Diesel)

TURBO FRAME DIMENSIONS

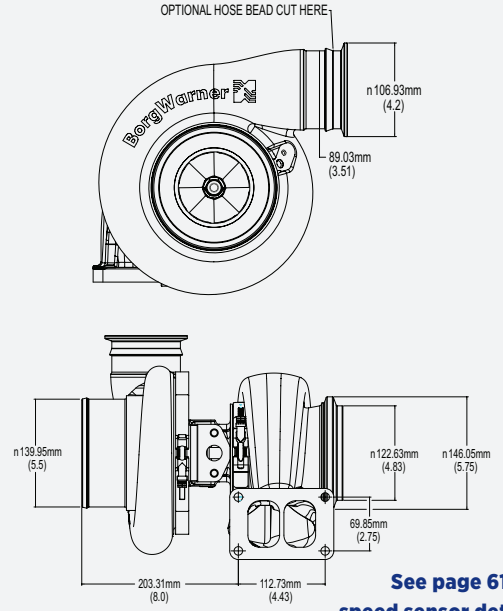

See page 61 for speed sensor details

S410SX – BIG BORE UPGRADE

Turbo	Comp. Wheel O.D. (in)	Comp Wheel O.D. (mm)	Comp Wheel Inducer Dia. (in)	Comp Wheel Inducer Dia. (mm)	Turbine Wheel O.D. (in)	Turbine Wheel O.D. (mm)	Turbine Wheel Exducer (in)	Turbine Wheel Exducer (mm)	Turbine Housing A/R	Super Core	Service Kit (360° thrust bearing)
14969880000	4.14	105.12	3.08	78.28	3.77	95.70	3.47	88.05	1.32	14007100002	14007110003
14969880001	4.32	109.73	3.16	80.30	3.77	95.70	3.47	88.05	1.58	14007100003	14007110003
14969880002	4.32	109.73	3.16	80.30	3.77	95.70	3.47	88.05	1.65 WG	14007100003	14007110003
14969880003	4.32	109.73	3.24	82.20	3.77	95.70	3.47	88.05	1.65 WG	14007100004	14007110003

Super Core	Comp. Wheel O.D. (in)	Comp Wheel O.D. (mm)	Comp Wheel Inducer Dia. (in)	Comp Wheel Inducer Dia. (mm)	Turbine Wheel O.D. (in)	Turbine Wheel O.D. (mm)	Turbine Wheel Exducer (in)	Turbine Wheel Exducer (mm)	Cartridge Assembly	Service Kit (360° thrust bearing)
14007100002	4.14	105.12	3.08	78.28	3.77	95.70	3.47	88.05	14009097002	14007110003
14007100003	4.32	109.73	3.16	80.30	3.77	95.70	3.47	88.05	14009097003	14007110003
14007100004	4.32	109.73	3.24	82.20	3.77	95.70	3.47	88.05	14009097004	14007110003

S410SX – BIG BORE UPGRADE

Turbo	Comp. Wheel O.D. (in)	Comp Wheel O.D. (mm)	Comp Wheel Inducer Dia. (in)	Comp Wheel Inducer Dia. (mm)	Turbine Wheel O.D. (in)	Turbine Wheel O.D. (mm)	Turbine Wheel Exducer (in)	Turbine Wheel Exducer (mm)	Turbine Housing A/R	Super Core	Service Kit (360° thrust bearing)
14969880004	4.14	105.12	3.08	78.28	3.77	95.70	3.47	88.05	1.32	14007100005	14007110003
14969880005	4.32	109.73	3.16	80.30	3.77	95.70	3.47	88.05	1.58	14007100006	14007110003

Super Core	Comp. Wheel O.D. (in)	Comp Wheel O.D. (mm)	Comp Wheel Inducer Dia. (in)	Comp Wheel Inducer Dia. (mm)	Turbine Wheel O.D. (in)	Turbine Wheel O.D. (mm)	Turbine Wheel Exducer (in)	Turbine Wheel Exducer (mm)	Cartridge Assembly	Service Kit (360° thrust bearing)
14007100005	4.14	105.12	3.08	78.28	3.77	95.70	3.47	88.05	14009097002	14007110003
14007100006	4.32	109.73	3.16	80.30	3.77	95.70	3.47	88.05	14009097003	14007110003

TURBINE HOUSING

Part #	A/R	Inlet Configuration		Notes
14961019007	1.15	Volute, Twin Flow	T6 Inlet	96mm Turbine Wheel
171698	1.32			
14961016101	1.45			
14961016100	1.58			

BV50

Porsche 997 Upgrade

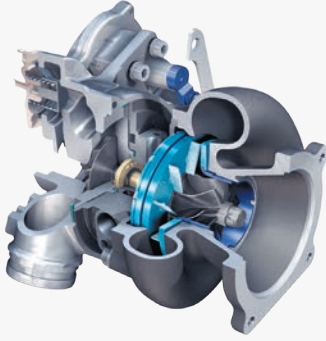

TURBO FRAME DIMENSIONS

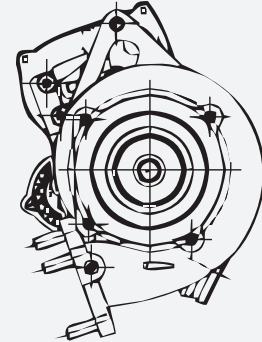
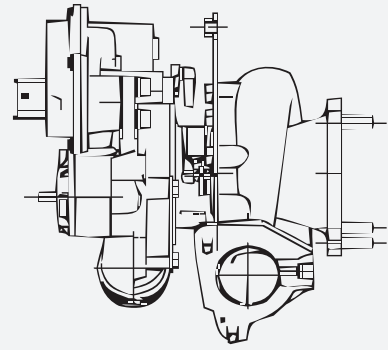

FEATURES

BorgWarner was the first manufacturer in the world to offer VTG turbochargers for gasoline engines in mass production. BV turbos employ materials and designs that are optimally tuned to the high thermal loads in gasoline engines. BorgWarner has developed a robust VTG mechanism that works reliably even in the toughest of conditions and also employ a CFD-Optimized vane design that provides excellent efficiency.

Manufacturer	Vehicle	Reference No.	Year	HP	Liters	Service Turbo No.	Model Spec	Remarks
Porsche	911 Turbo (997)	997.123.014.72	2005	480	3.6	5304 988 0302	BV50-2277	Stock Turbo (Right Side)
Porsche	911 Turbo (997)	997.123.013.72	2005	480	3.6	5304 988 0301	BV50-2277	Stock Turbo (Left Side)
Porsche	911 GT2 (997)	997.123.078.71	2007	530	3.6	5304 988 0304	BV50-2280	Upgrade Turbo (Right Side)
Porsche	911 GT2 (997)	997.123.014.70	2007	530	3.6	5304 988 0303	BV50-2280	Upgrade Turbo (Left Side)

TURBO COMPARISON

~ VTG ~ Wastegate

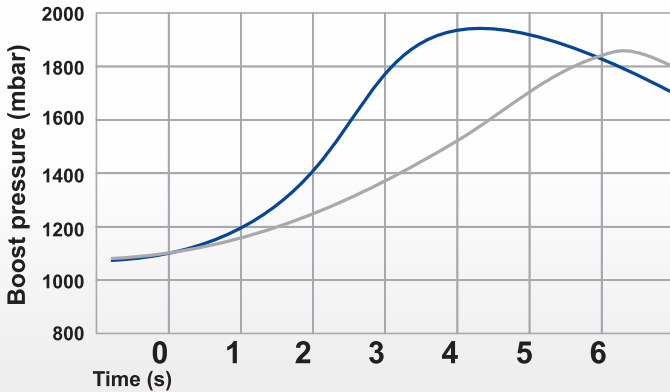

PORSCHE 911 GT2 (997)

TSG-1 Turbo Speed Gauge

Buying a high-quality turbocharger isn't cheap. But you know what can make it even more expensive? Allowing your turbocharger to get damaged by overspeeding for an extended period of time. Fortunately, the TSG-1 Turbo Speed Gauge monitors turbo speed to protect your investment in your turbocharger.



WHAT IS THE TSG-1?

The Turbo Speed Gauge TSG-1 is a compact, 2 1/16" circular gauge that can be easily attached to the dashboard, A-pillar, instrument cluster or a variety of other locations. The gauge is designed for use with the turbo speed sensor integrated into all BorgWarner EFR and many Airwerks series turbos.

Using a speed sensor attached to the turbocharger, the gauge accurately displays turbo speed in both numeric and graphical formats. Whenever turbo speed exceeds the safe limit and the turbo begins to overspeed, the TSG-1's screen flashes, instantly notifying the driver.

TSG-1 SPECIFICATIONS

- Compact 2 1/16" circular gauge
- 128 x 64 pixel graphical display
- Pairs with turbo speed sensor
- 12-bit 0-5 volt analog input for MAP / pressure sensors
- 12-bit 0-5 volt analog output for ECU and/or datalogging



TSG-1

HARDWARE INTERFACE SCHEMATIC

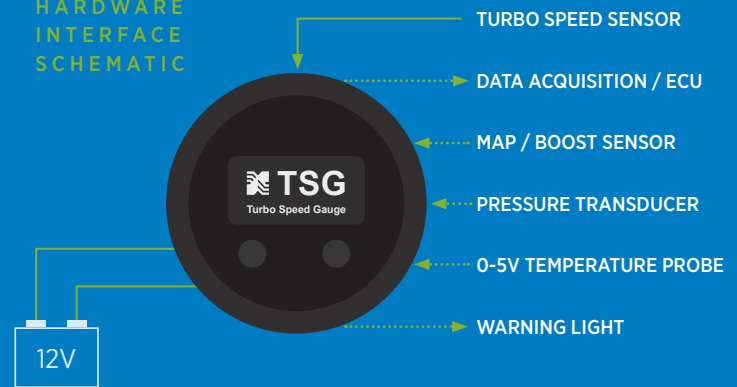

INPUT & OUTPUT CAPABILITIES

The TSG-1 analog input can capture and display data from auxiliary sensors such as MAP/Boost sensor, oil or fuel pressure and more.

The TSG-1 generates a 12-bit 0-5 volt analog turbo speed signal that

can be connected to an engine control system or datalogger.

The TSG-1 also generates a warning output signal during overspeed events that can illuminate a warning light or trigger a relay or other device.

OPTIONAL SPEED SENSOR, BOOST PORT AND V-BAND CONNECTIONS

INSTRUCTIONS

Select BorgWarner turbochargers offer convenient pre-machined options to help users get the most out of their turbocharger in terms of customization and installation needs. These additional features require the user to perform some basic drilling, cutting and de-burring. Please seek help if you are uncomfortable with these operations.

SPEED SENSOR & BOOST PORT

1. Carefully remove the compressor cover from turbo.
2. Place cover on a table, with some kind of backing so that it is secure while being drilled.
3. Using a hand drill with a 1/4" drill bit, drill through bottom of speed sensor or boost port hole while being careful not to damage the pre-machined speed sensor O-ring sealing surface or the boost port threads.
4. De-burr the inside edge of the hole in the compressor cover.
5. **SPEED SENSOR:** Lubricate O-ring and install speed sensor while checking for a good fit. Ensure that the sensor tip is nearly flush with the edge of the hole (within .5mm/.020") and install speed sensor bolt.
BOOST PORT: Install 1/8 - 27 NPT boost fitting with thread sealant or Teflon tape and ensure the joint is leak free.
6. Carefully re-install compressor cover on turbo and verify that the compressor wheel spins freely.

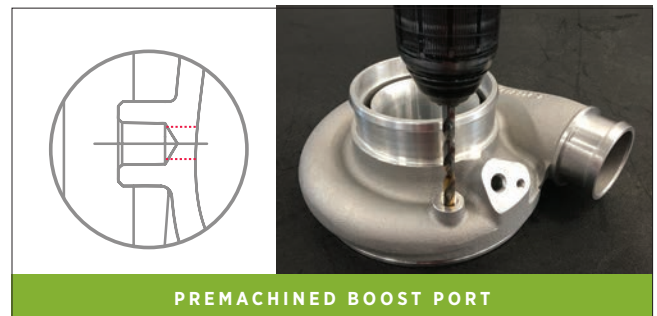
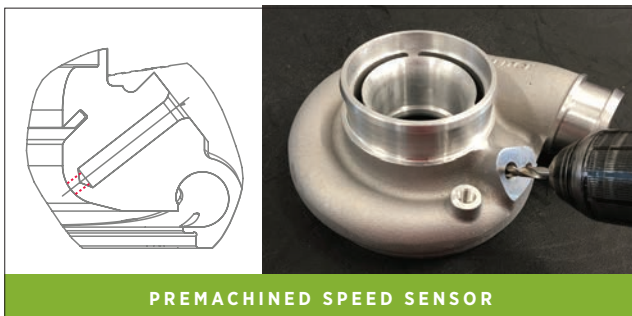

OPTIONAL V-BAND OR HOSE BEAD

1. Carefully remove the compressor cover from turbo.
2. Secure compressor cover and remove connection feature with a straight, clean cut. Reference the drawings below. Be sure to remove all sharp edges when complete.
3. Carefully re-install the compressor cover on turbo and verify that the compressor wheel spins freely.

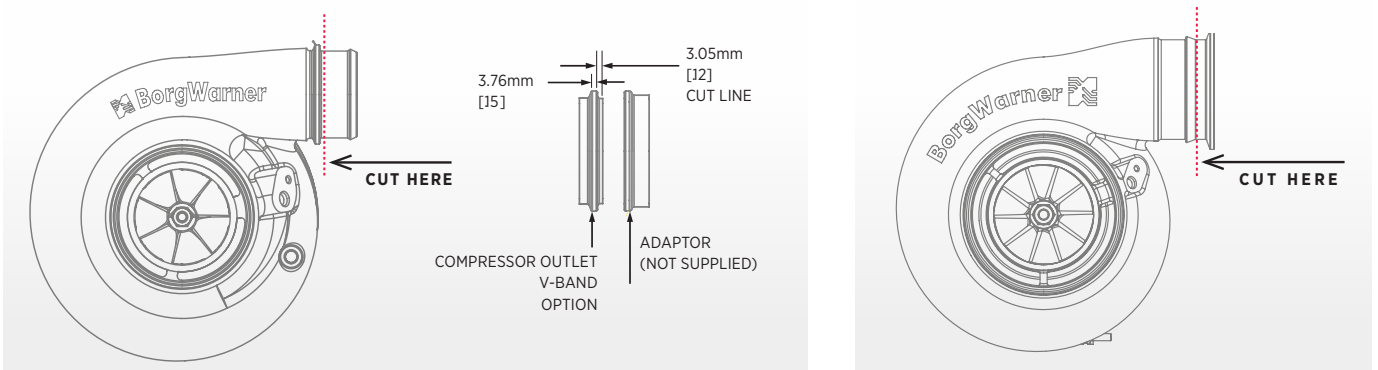

BorgWarner Turbos for Upgraded Passenger Car Engines

OEM	Vehicle	Build Date	Engine	Stock Turbo(s)	Original Rating	Stock Turbo Limit
Audi	various vehicles with longitudinal engine	up to 1999	1.8T 20V	K03-005, K03-013	150 hp	195 hp
Audi	various vehicles with transverse engine	up to 2000	1.8T 20V	K03-011, K03-026, K03-035, K03-044, K03-045	150-180 hp	200 hp
Audi	various vehicles with longitudinal engine	from 2000	1.8T 20V	K03-025, K03-029	150-180 hp	200 hp
Audi	various vehicles with transverse engine	from 2004	2.0 TFSI	K03-086, K03-105 (integrated manifold)	185-200 hp	245 hp
Audi	A4	from 2007	1.8 TFSI	K03-119, K03-141 (integrated manifold)	120-160 hp	220 hp
Audi	various		1.8T 20V	various K03, K04	150-225 hp	-
Audi	various		1.8T 20V	various K03, K04	150-225 hp	-
Audi	S4, A6, allroad		2.7T 30V biturbo	K03-016 + K03-017	230-265 hp	315 hp
Ford	Focus ST/XR5, Kuga, Mondeo, S-Max	from 2003	HUBA, HUWA, HYDA, B5254	K04-033, K04-130 (integrated manifold)	200-230 hp	305 hp
Mini	Cooper S	from 2006	EP6 DTS/ CDTS	K03-118, K03-181 (twin-scroll turb/hsg)	163-184 hp	220 hp
Mini	Cooper S	from 2009	EP6 DTS/ CDTS	K03-163 (twin-scroll turb/hsg)	163-200 hp	220 hp
Opel	Astra, Zafira	from 2000	Z20LET	K04-024	190-200 hp	240 hp
Opel	Astra, Zafira	from 2005	Z20LER, Z20LEL	K04-048	170-200 hp	240 hp
Peugeot, Citroen	207, 208, DS3	from 2006	EP6 DT/ CDT	K03-104, K03-120, K03-121 (twin-scroll turb/hsg)	140-156 hp	180 hp
Peugeot, Citroen	308, RCZ, DS4	from 2009	EP6 DTS/ CDTS	K03-163 (twin-scroll turb/hsg)	163-200 hp	220 hp
Peugeot, Citroen	207, 208, DS3	from 2009	EP6 DT/ CDT	K03-179, K03-217, K03-243 (twin-scroll turb/hsg)	140-156 hp	180 hp
Porsche	911 turbo (model 993)	1994 to '97	3.6 biturbo	K16-6735 + K16-6736	408 hp	500 hp
Porsche	911 turbo (model 996)	2000 to '05	3.6 biturbo	K16-6726 + K16-6727	420 hp	500 hp
Porsche	911 turbo (model 997)	from 2005	3.6 biturbo	K04-0060 + K04-0061 (VTG)	480 hp	575 hp
Seat	Alhambra	up to 2000	1.8T 20V	K03-022	150 hp	195 hp
Seat	Alhambra	from 2000	1.8T 20V	K03-049	150 hp	200 hp
Seat/Skoda	various		1.8T 20V	various K03, K04	150-225 hp	-
Seat/Skoda	various		1.8T 20V	various K03, K04	150-225 hp	-
VW	various vehicles with longitudinal engine	up to 1999	1.8T 20V	K03-005, K03-013	150 hp	195 hp
VW	Sharan	up to 2000	1.8T 20V	K03-022	150 hp	195 hp
VW	Sharan	from 2000	1.8T 20V	K03-049	150 hp	200 hp
VW	various vehicles with transverse engine	up to 2000	1.8T 20V	K03-011, K03-026, K03-035, K03-044, K03-045	150-180 hp	200 hp
VW	various vehicles with transverse engine	up to 2000	1.8T 20V	K03-011, K03-026, K03-035, K03-044, K03-045	150-180 hp	200 hp
VW	various vehicles with longitudinal engine	from 2000	1.8T 20V	K03-025, K03-029	150-180 hp	200 hp
VW	various		1.8T 20V	various K03, K04	150-225 hp	-
VW	various		1.8T 20V	various K03, K04	150-225 hp	-
VW	various vehicles with transverse engine	from 2004	2.0 TFSI	K03-086, K03-105 (integrated manifold)	185-200 hp	245 hp
Volvo	C30, S40, V50, XC60, C70	from 2003	T3 / T6 / T7 / T8	K04-033, K04-130 (integrated manifold)	200-230 hp	305 hp

Upgrade Turbo	Plug & Play	Upgrade Turbo Limit	Max. T3 continuously	Max. T3 temporarily
5304 988 7500	yes	225 hp	930°C	950°C
5304 988 7501	yes	230 hp	930°C	950°C
5304 988 7500	yes	225 hp	930°C	950°C
5304 988 0064	yes**	305 hp	1025°C	1050°C
5303 988 0106	yes	245 hp	930°C	950°C
5316 988 6717	NO	250 hp	950°C	980°C
5324 988 7200	NO***	340 hp	950°C	980°C
5304 988 0025 + 5304 988 0026	yes	475 hp	930°C	950°C
5316 998 0010	yes*****	375 hp	950°C	980°C
5303 988 0146	yes****	245 hp	950°C	980°C
5303 988 0298	yes	245 hp	950°C	980°C
5304 998 0049	yes*****	290 hp	930°C	950°C
5304 998 0049	yes	290 hp	930°C	950°C
5303 988 0117	yes	220 hp	950°C	980°C
5303 988 0298	yes	245 hp	950°C	980°C
5303 988 0426	yes	220 hp	950°C	980°C
5324 988 7003 + 5324 988 7004	yes	555 hp	950°C	980°C
5324 988 7005 + 5324 988 7006	yes	555 hp	950°C	980°C
5304 998 0304 + 5304 988 0303	yes	610 hp	950°C	980°C
5304 988 7500	NO*	225 hp	930°C	950°C
5304 988 7500	NO*	225 hp	930°C	950°C
5316 988 6717	NO	250 hp	950°C	980°C
5324 988 7200	NO***	340 hp	950°C	980°C
5304 988 7500	yes	225 hp	930°C	950°C
5304 988 7500	NO*	225 hp	930°C	950°C
5304 988 7500	NO*	225 hp	930°C	950°C
5304 988 7501	yes	230 hp	930°C	950°C
5304 988 7501	yes	230 hp	930°C	950°C
5304 988 7500	yes	225 hp	930°C	950°C
5316 988 6717	NO	250 hp	950°C	980°C
5324 988 7200	NO***	340 hp	950°C	980°C
5304 988 0064	yes**	305 hp	1025°C	1050°C
5316 998 0010	yes*****	375 hp	950°C	980°C

*Compressor housing orientation different.

**Original turbo has electronic pop-off valve integrated into comp/hsg, upgrade turbo has not.

External pop-off valve has to be fitted. Moreover, KO4-064 has a larger compressor housing discharge.

***Upgrade turbo without wastegate, external wastegate required.

****Turbine housing outlet gasket with BMW OE part no. 7 589 503 required.

*****Piece of coolant pipe already fitted, may require adaptation of coolant piping.

*****Slightly different position and size of compressor discharge.

K03-2080

Mini Upgrade

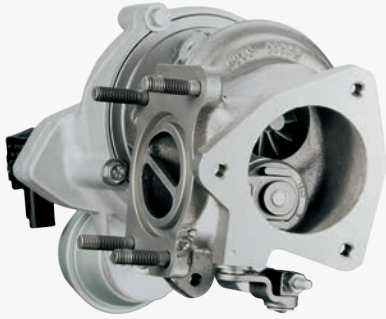

TURBO FRAME DIMENSIONS

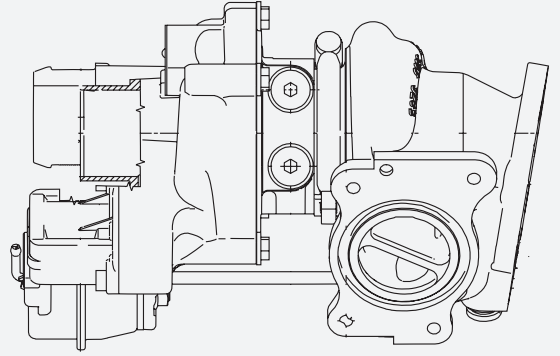

FEATURES

- High temperature alloy turbine housing
- Extended tip compressor wheel
- Twin scroll turbine housing
- Water cooled bearing housing

Turbo Part #	Comp. Wheel O.D. (mm)	Comp Wheel Inducer Dia. (in)	Comp Wheel Inducer Dia. (mm)	Turbine Wheel O.D. (in)	Turbine Wheel O.D. (mm)	Turbine Wheel Exducer (in)	Turbine Wheel Exducer (mm)	Turbo Area	Cartridge Assembly	Service Kit
5303 988 0146	51.00	1.61	41	1.77	45	1.58	40.3	4 cm ²	-	-

Manufacturer	Year	Engine	Stock Turbo	Stock Turbo	Upgrade HP	Upgrade Turbo Part #	Model Spec	Remarks
Mini	From 2006	EP6 DTS	5303 988 0163	215	255	5303 988 0146	K03-2080	Twin Scroll Turbine Housing



MINI COOPER

K04-2075

220 HP Turbo

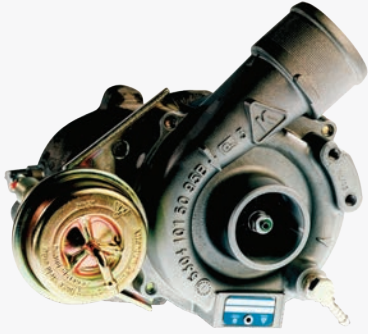

FEATURES

How about a BorgWarner AirWerks K04 series performance upgrade turbo, developed specifically for Audi and VW 1.8 liter engines? This upgrade option can enhance engine performance as much as 15%. Ultimate output may vary depending on prior engine condition, fuel settings and other supporting performance components. Only qualified companies and tuner shops should attempt to make performance modifications to the engine and the vehicle.

TURBO FRAME DIMENSIONS

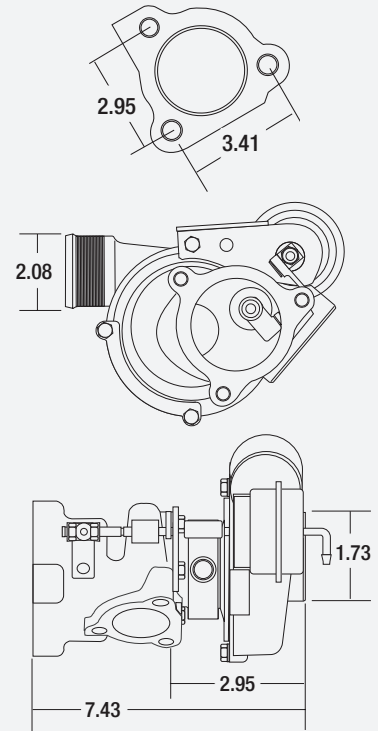

Turbo Part #	Comp. Wheel O.D. (in)	Comp. Wheel O.D. (mm)	Comp Wheel Inducer Dia. (in)	Comp Wheel Inducer Dia. (mm)	Turbine Wheel O.D. (in)	Turbine Wheel O.D. (mm)	Turbine Wheel Exducer (in)	Turbine Wheel Exducer (mm)	Turbine Area	Cartridge Assembly	Service Kit
5304 988 7500	1.97	50.04	1.48	37.60	1.81	46	1.65	42	4 cm ²	5304 710 0503	5303 711 0000

COMPRESSOR MAP

Comp. Wheel Inducer Dia. (mm) 37.60
Comp. Wheel Outer Dia. (mm) 50.04

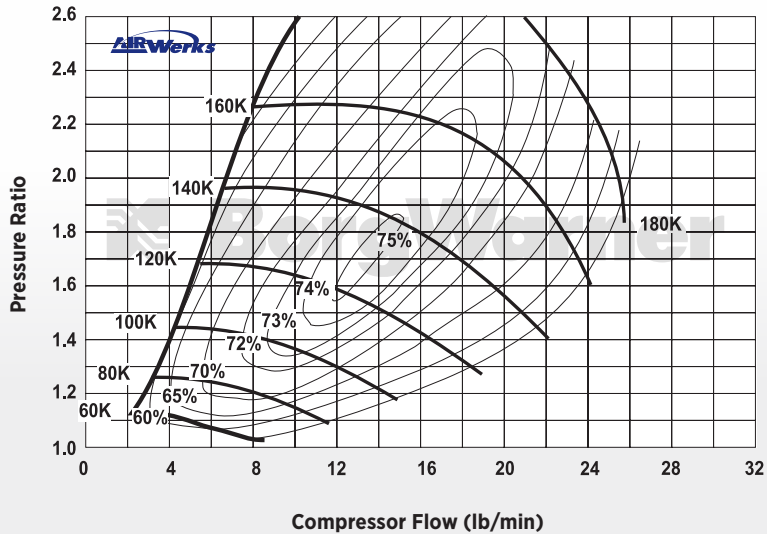

VEHICLE APPLICATION DATA

Application Model	Model Year	Engine Spec	Rated HP
Audi A4 A6 / 1.8T	95-99	1.8 liter 5-Valve, Inline	220
Passat	96-99	1.8 liter 5-Valve, Inline	220

K04-2075

220 HP Turbo



FEATURES

How about a BorgWarner AirWerks K04 series performance upgrade turbo, developed specifically for Audi and VW 1.8 liter engines? This upgrade option can enhance engine performance as much as 15%. Ultimate output may vary depending on prior engine condition, fuel settings and other supporting performance components. Only qualified companies and tuner shops should attempt to make performance modifications to the engine and the vehicle.

TURBO FRAME DIMENSIONS

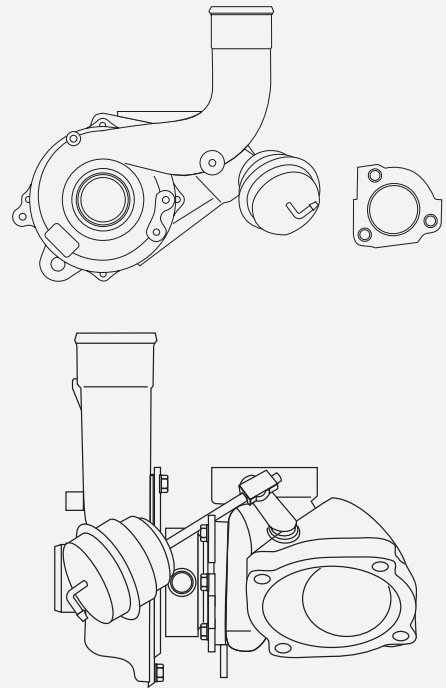

Turbo Part #	Comp. Wheel O.D. (in)	Comp. Wheel O.D. (mm)	Comp Wheel Inducer Dia. (in)	Comp Wheel Inducer Dia. (mm)	Turbine Wheel O.D. (in)	Turbine Wheel O.D. (mm)	Turbine Wheel Exducer (in)	Turbine Wheel Exducer (mm)	Turbine Area	Cartridge Assembly	Service Kit
5304 988 7501	1.97	50.04	1.48	37.60	1.81	46	1.65	42	5 cm ²	N/A	5303 711 0000

COMPRESSOR MAP

Comp. Wheel Inducer Dia. (mm) 37.60
Comp. Wheel Outer Dia. (mm) 50.04

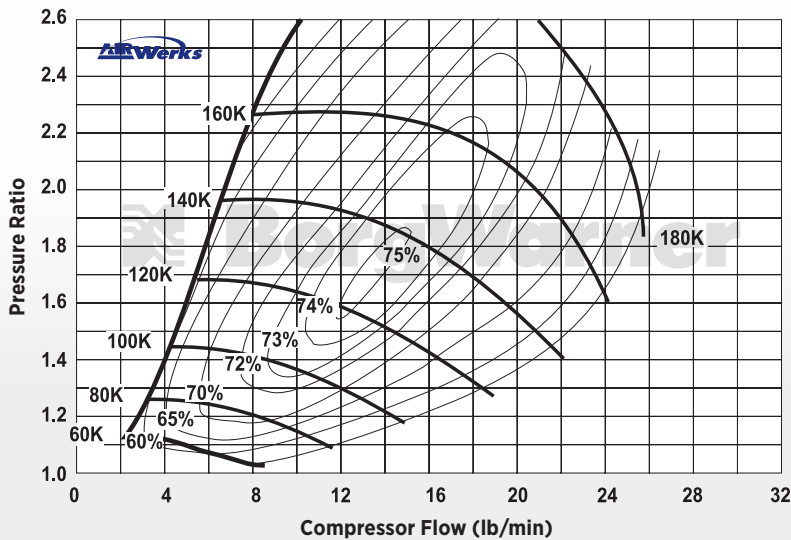

VEHICLE APPLICATION DATA

Application Model	Model Year	Engine Spec	Rated HP
Audi A3 1.8T, VW Beetle	96-01	1.8 Liter 5-Valve, Transverse	220
Golf	1996	1.8 Liter 5-Valve, Transverse	220

K04-2283

325 Peak Horsepower



F E A T U R E S

- High-temperature alloy turbine housing
- Extended tip compressor wheel
- Water cooled bearing housing

***Upgrade turbo does not come with a compressor recirculation valve or the mounting detail for one. An external valve will have to be used.**

TURBO FRAME DIMENSIONS

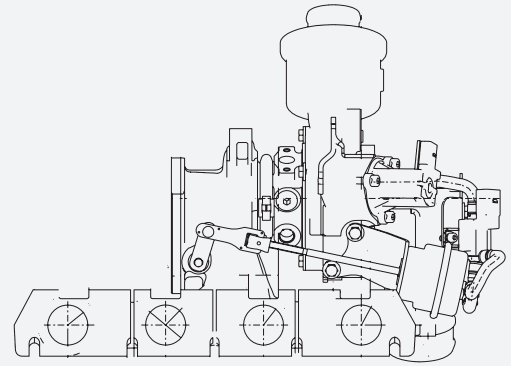

The electrical recirculation valve, which is also integrated into the compressor casing, guarantees fast response times when closing the throttle valve. The use of a “latest generation” turbine wheel helps increase the efficiency of the turbocharger significantly, while optimized thermodynamics have led to further improvements in fuel consumption and transient behavior, i.e. the acceleration of the engine at full throttle. **Original turbo has electronic pop-off valve integrated into comp/hsg, upgrade turbo has not. External pop-off valve has to be fitted.** Moreover, K04-064 has a larger compressor housing discharge.

Manufacturer	Vehicle	Year	Engine	Stock Turbo	Stock Turbo HP Limit	Upgrade HP	Upgrade Turbo Part #	Model Spec	Remarks
Audi	A3	From 2004	2.0 TFSI	5303 988 0105	255	325	5304 988 0064*	K04-2283D	Integrated Manifold
Audi	A3	From 2003	2.0 TFSI	5303 988 0086	255	325	5304 988 0064*	K04-2283D	Integrated Manifold



A U D I A 3

K16-2480

370 Peak Horsepower



FEATURES

- High-temperature alloy turbine wheel
- Extended tip compressor wheel
- Water cooled bearing housing

TURBO FRAME DIMENSIONS

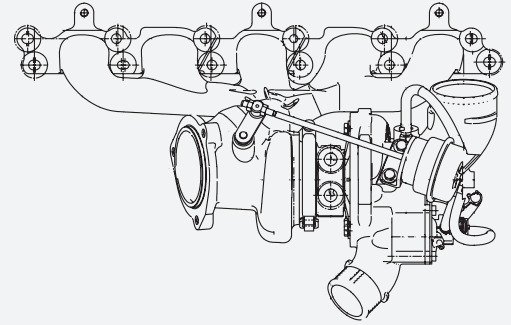

Volvo's requirement for the developers at BorgWarner was to replace the bi-turbo boosting of the previous engine with a new unit with single-turbo boosting. The new 6-cylinder engine also had to possess at least the same transient response as its predecessor, and of course fuel consumption and emissions needed to be brought up to date. With the K16 used in the Volvo 6-cylinder engine, BorgWarner unveils the first in a wide range of turbos for gasoline engines displacing from 1.6 to 3.0 liters or between 150 and 285 bhp.

Manufacturer	Vehicle	Year	Engine	Stock Turbo	Stock Turbo HP Limit	Upgrade HP	Upgrade Turbo Part #	Model Spec	Remarks
Volvo	S40/V50/XC60/C70	From 2003	2.5L RNC-RS	5304 988 0033	300	370	5316 998 0010	K16-2480D	Integrated Manifold
Ford	Focus	From 2005	2.5L RNC-RS	5304 988 0033	300	370	5316 998 0010	K16-2480D	Integrated Manifold



V O L V O

Warranty Statement

LIMITED WARRANTY:

BorgWarner Turbo Systems, Inc. (“BWTS”) warrants that its goods or merchandise will be free from defects in material and workmanship for its intended use and service. This warranty shall extend for a period of twelve (12) months from the date of purchase by end user. BWTS will repair or provide a replacement product, at BWTS’s sole option, for any defective part. Replaced parts will be warranted in time only through the remaining period of this warranty. BWTS shall not be obligated to repair or replace any defective part unless it receives notice, in writing, within 14 days of discovery of a defect. Any action for breach of warranty, contract or otherwise, shall be barred unless BWTS is provided with notice as provided herein. Specifically excluded from this warranty are design defects or damage caused by improper installation, misuse, neglect, improper maintenance,

handling or operation of the product or unauthorized repair or alterations or externally induced physical damage.

Further, this warranty shall not apply if any person attempts to repair or replace the defective part without BWTS written authorization. Any auxiliary equipment sold hereunder and not manufactured by BWTS carries only such warranty as given by the manufacturer thereof and which is hereby assigned without recourse to BWTS. No warranty is made for any other claims or special, indirect or consequential damages (including but not limited to component removal or installation, equipment down time, prospective profits or other economic losses) because of any defect deemed warrantable by BWTS.

This is BWTS’s sole warranty and is in lieu of all other warranties, express or implied, including, without

limitation, implied warranty of merchantability, or fitness for a particular purpose.

No representative or distributor of BWTS has the authority to change or alter this warranty. This warranty may only be modified by an agreement signed by an authorized officer of BWTS.

Any claim made under this limited warranty must be presented to BWTS, with valid proof of date of purchase by end-user. All merchandise or goods shipped to BWTS, for warranty consideration, must be shipped prepaid - freight. Collect shipments will be refused.

No warranty on competition applications or applications not approved in writing by BorgWarner Turbo Systems.



WARNING: Cancer and Reproductive Harm – <http://www.p65warnings.ca.gov>



BorgWarner Turbocompounders





Will Power
2018 INDY 500® WINNER

Indy 500 and Indianapolis Motor Speedway are registered trademarks of Brickyard Trademarks, Inc., used with permission.

Innovation



WORLDWIDE HEADQUARTERS

Kirchheimbolanden, Germany

starts here

“In our history, we have produced over 110 million turbochargers and are still learning new things every day. With our manufacturing footprint, we also secure proximity to our customers and offer specific expertise in the various market segments for which we produce.”

JOE FADOOL,

President of BorgWarner Turbo Systems

TURBO SYSTEMS FACILITIES

Asheville, North Carolina
Bradford, UK
Itatiba, Brazil
Kirchheimbolanden, Germany
Ningbo, China
Oroszlany, Hungary
Pyongteak, South Korea
Ramos-Arizpe, Mexico
Rzeszow, Poland



TURBOCHARGER FACILITY

Asheville, North Carolina

BorgWarner Inc.

North America

info-NA@borgwarner.com

Europe

info-EU@borgwarner.com

borgwarnerboosted.com