



Turbonetics

A **Wabtec** company

turboneticsinc.com



2016 PRODUCT CATALOG





Introduction

Since 1978, Turbonetics has been a leader in designing and manufacturing turbochargers, intercoolers, turbo systems, pressure control valves and forced induction components. Turbonetics products are boosting engines that run on all kinds of fuel, and in all sorts of environments including performance, racing, industrial and military applications. Our commitment to quality and innovation and our ability to design and deliver customized solutions within days makes Turbonetics products the number one choice for daily driven performance vehicles as well as extreme race-only applications from as little as 250 to over 2000 horsepower on a single turbo.

But with a Turbonetics product you get more than just performance, you get peace of mind that what you install has been made to the highest quality standards, with years of experience in designing and producing forced induction parts. If something were to go wrong, our legendary no fault no hassle warranty would have you covered. We are here to help to get you back behind the wheel quickly.

Our range of Turbonetics' turbos comes with a mind-boggling choice of compressor wheels, turbine wheels and end housing configurations. We listed as much as possible, but if you cannot find what you are looking for, contact us for an even more customized turbocharger or intercooler. We are constantly adding new products and options to our portfolio, make sure to visit www.turboneticsinc.com for the latest innovations as well as technical information.



14399 PRINCETON AVE, MOORPARK, CA 93021
TEL : (805) 581- 0333/FAX:(805) 584-1913





Table of Contents

INTRODUCTION	2
TABLE OF CONTENTS	3
CERAMIC BALL BEARING TECHNOLOGY	4
WARRANTY POLICY	5
COMPONENT AND ASSEMBLY BALANCING	6
COMPRESSOR AND TURBINE WHEELS	7
HOW TO CHOOSE A TURBO	8
A/R RATIO AND TWIN TURBO	9
HOW TO READ A COMPRESSOR MAP	10-11
INDUSTRIAL/MILITARY/UNMANNED SOLUTIONS	12-14
TNX SERIES TURBOCHARGERS	15-17
GT-K BILLET TURBOCHARGERS	18
HURRICANE SERIES TURBOCHARGER	19
T-SERIES TURBOCHARGERS	20
MID-FRAME TURBOCHARGERS	21
Y2K/SUPER THUMPER TURBOCHARGERS	22
TURBINE OPTIONS	23
INTERNALLY WASTEGATED TURBINE HOUSINGS	24
WHEEL DIMENSIONS AND TRIM	25
TURBINE HOUSING FLANGES AND GASKETS	26
TURBINE HOUSING HEATSHIELDS AND V-BANDS	27
OIL SUPPLY - GASKETS AND FLANGES	28
PARTS & ACCESSORIES	29-30
EXTERNAL WASTEGATES	31-32
BLOW OFF VALVES AND BOOST CONTROLLERS	33
SILICONE CONNECTIONS AND T-BOLT CLAMPS	34
INTERCOOLER SELECTION GUIDE/SPEARCO	35
AIR TO AIR INTERCOOLER CORES	36-41
LIQUID TO AIR INTERCOOLER CORES	42-44
MITSUBISHI EVOLUTION X INTERCOOLER KIT	45
SUBARU WRX/STI INTERCOOLER KIT	46
CHEVROLET CAMARO TURBO SYSTEMS	47
GM DURAMAX DIESEL UPGRADES	48
FORD POWERSTROKE DIESEL UPGRADES	49
DODGE CUMMINS DIESEL UPGRADES	50
TERMS & CONDITIONS/RMA INSTRUCTIONS	51



Turbonetics

A Wabtec company

Ceramic Ball Bearing Technology

What makes the Turbonetics ball bearing special?

Turbonetics offers a patented Angular-Contact Ceramic Ball Bearing design. This Turbonetics exclusive design is made with almost indestructible silicone-nitride ceramic balls. A conventional unit has a capacity of 60-80 lbs. of dynamic thrust load. The patented Turbonetics Angular-Contact Ceramic Ball Bearing can withstand anywhere from 1000 to 2200 lbs. of loading. The “angular-contact” feature offers extreme strength because it is used as the loading surface. This results in quicker transient response and ultra-fast spooling of the turbo. With Turbonetics Angular-Contact Ceramic Ball Bearing units, you will build boost faster at the line, reach boost sooner in the RPM band and maintain higher boost in between shifts.

Turbonetics Ball Bearing Serviceability

While most of our turbos never require any repairs, many of our customers love to have peace of mind when it comes to serviceability. Our unique design allows all genuine Turbonetics Ball Bearing units to be rebuilt for less than the cost of a new unit. Contact your dealer or call us if you need to service your unit.



**WITH PATENTED
CERAMIC BALL BEARING
TECHNOLOGY**

- MORE THAN 13X GREATER THRUST CAPACITY
- 25% FASTER SPOOL UP
- RE-BUILDABLE
- PATENTED CERAMIC BALL BEARINGS



Every Turbonetics turbocharger from TNX-20 to T-Series comes preinstalled with a special in-line oil filter to prolong your turbo's life and protect it from oil debris damage. See page 51 for complete warranty details.

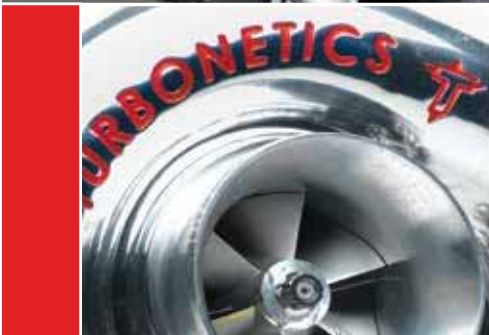

Call Turbonetics Customer Service Department at 805-581-0333.

Please Provide:

- Warranty Registration Number
- RGA (Returned Goods Authorization) number supplied by Turbonetics clearly marked on outside of box
- Description regarding failure or damage to the component
- Mileage
- Point of purchase

Company Warranty Policy

The “No Fault/No Hassle” Warranty

We at Turbonetics stand behind our products. And our “No Fault/No Hassle” warranty program shows this commitment.

We will repair or replace any Turbonetics product that fails, including products used in racing or competition applications, for a period of one year from the original date of purchase. Any defect in material or workmanship is covered - no questions asked. This truly exceptional warranty program offers peace-of-mind that when you get a Turbonetics product, you get our commitment to quality and performance. See page 51 for exclusions and details on how to submit a claim.

Engineering

- In-depth aerodynamic and turbocharger engineering expertise
- Custom aerodynamic matching application
- CAD expertise to turn ideas into products quickly

Research & Development

- Expert tuning capability
- Skillful custom fabrication
- Dynamometers on site
- Gas stand performance testing

Sales & Tech Support

- Friendly sales staff
- Excellent tech support
- Dedicated customer service

Manufacturing

- In house machining and assembly
- Component and VSR assembly balancing
- Fully trained & certified technicians

Quality

- Disciplined quality management system
- Caterpillar SQEP gold certified

Shipping

- FedEx, UPS, DHL and freight forwarding
- Competitive rates
- Same day shipping for in stock items





Component & Assembly Balancing

Turbochargers can spin at speeds of well over 100,000 rpm. The slightest imbalance can cause vibration, leading to noisy operation, oiling issues and ultimately bearing failure. Just like the wheels on a car, the wheels on a turbocharger have to be balanced to ensure optimal performance.

There are two ways on how a turbocharger can be balanced: Component balancing and VSR or “Assembly” balancing. While many turbocharger manufacturers choose one or the other method, at Turbonetics we believe that the perfect turbocharger has to be perfectly balanced. This can only be achieved by using both methods - on every turbocharger possible.

Step 1: Component Balancing

When using a component balancer, both the turbine wheel and the compressor wheel are balanced individually - prior to being assembled into the turbocharger. The wheels are run at relatively low speeds, just like new tires at a tire shop. But unlike tires, where weight is added to achieve balance, tiny amounts of metal are removed from turbocharger wheels through precision milling and grinding to achieve the perfect balance.

VSR HIGH SPEED BALANCING PROCESS

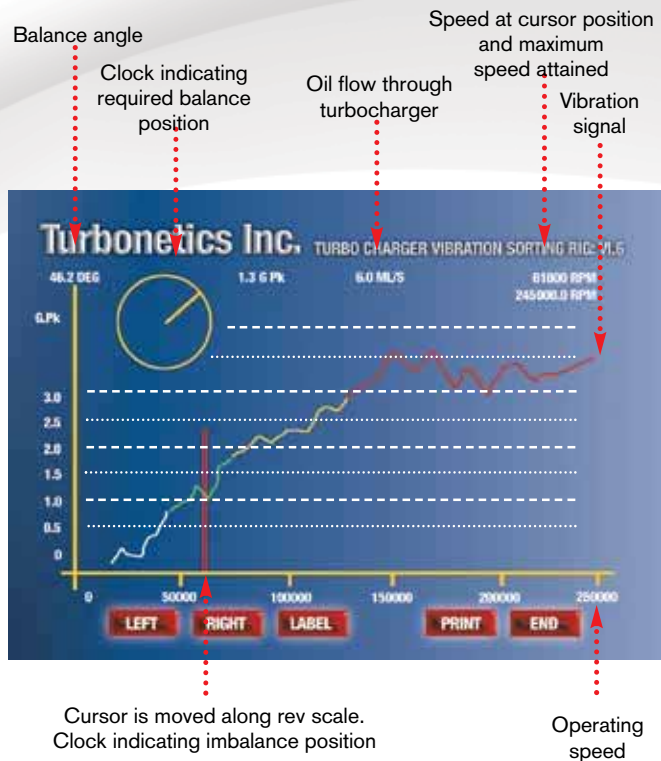

Step 2: VSR or “Assembly” balancing

The second method is called VSR (Vibration Sorting Rig) balancing. This machine detects imbalance of the complete unit after assembly. As turbos are assembled, there are still tiny imperfections in thrust collars, nose nuts, wheels and shafts. While each one is adequately balanced by itself, once assembled together the sum of all the imbalances can become significant. Using the VSR process, a completed CHRA (Center Housing & Rotating Assembly - basically a turbocharger without end housings) is driven by compressed air in a VSR balancer, and accelerometers determine:

- The amount of imbalance
- The position of the imbalance
- Shaft rotating speed
- Oil flow volume through assembly

A certified technician then removes even tinier parts of metal, ensuring the perfect balance of the entire unit. The result is a perfectly balanced Turbonetics turbocharger that will run smoothly, perform better and live longer.



Compressor Wheel Design

Compressor wheels deliver pressurized air to the engine. Turbonetics compressor wheels are manufactured from one of three different materials: cast 354 aluminum that is heat treated and Hipped, A-2618 forged aluminum and Titanium depending on the application requirements. Computer aided design (CAD) allows for new blade designs to create maximum airflow efficiency and pressure. Racers and enthusiasts continue to strive for greater power and Turbonetics compressor wheel designs are constantly evolving to meet the demands and deliver higher boost pressures.

Our wide range of compressor wheel sizes, trim blade configurations and blade shapes can be categorized into three groups:

T-Series Based Wheels: Known for their outstanding durability and solid air flow characteristics, this category includes well established cast wheels such as T3, 60-1, 62-1, T04B, T04E.

HP (High Pressure) Wheels: To meet the need for higher boost pressures and efficiency, Turbonetics developed the HP- Series wheels with new blade shapes providing optimized air flow. Primarily cast components are under more stress than T-series based wheels, these wheels go through a process called Hot Isostatic Processing (HIP). This process removes any air bubbles that could be trapped in the castings. Imperfections in the castings can cause wheel bursts, and we are not prepared to compromise on durability.

HPC Wheels: The “C” stands for “Competition”. A further development over the HP wheels, these Turbonetics billet wheels provide even greater efficiency and airflow. To withstand the extreme pressures, HPC compressor wheels are machined from forged blanks instead of standard bar stock. Wheels machined from forged blanks have stronger blades and wheel hubs and allow maximizing airflow while minimizing rotating mass.

Turbine Wheel

Turbine wheels harness the hot exhaust gas energy for the turbocharger. All Turbonetics turbine wheels are made from 713C Inconel, a nickel-based super alloy. This material is much stronger and can withstand higher temperatures than most other turbine wheel materials. Turbonetics exclusive F1-series turbine wheels feature a 11-blade design and tall tip height configuration to maximize the exhaust gas energy and keep backpressures low. Backpressure is the opposite of boost pressure. It is the pressure of the exhaust gas trying to get past the turbine wheel. High backpressure can prevent optimum flow through the engine, limit the turbocharger from making boost and reduce potential horsepower. Unlike conventional T style turbine wheels, our T01-series design minimizes backpressure to allow the most horsepower possible for a given wheel size.



Turbonetics
NEW T01
turbine wheel
provides unequalled
exhaust flow while
keeping back
pressures low.



Turbonetics

A **Wabtec** company

New aerodynamics and improvements in blade design and materials are always in the works at Turbonetics.

Check our website for the latest updates and learn more about wheel diameters and trim at

www.turboneticsinc.com



F1-SERIES TURBINE WHEELS*

FAMILY	WHEEL	HORSEPOWER
T25/28	T01-43	300 NEW
T3	T01-48	350 NEW
T3	T01-55	450 NEW
T3 OR T4	T01-58	550 NEW
T3 OR T4	F1-68	1000
T4	F1-75	1150
MID-FRAME	F1-75	1200
MID-FRAME	F1-82	1250+ NEW
Y2K	F1-89	1200
Y2K	F1-101	1250
THUMPER	F1-96	1850
THUMPER	F1-106	1900
THUMPER	F1-112	2000

*Wheel names also denotes turbine exducer diameter in mm.



How to Choose a Turbo

There are many variables to consider when choosing the perfect turbo for your engine. This section will help narrow down your choice.

Visit www.turboneticsinc.com for more detailed information. Here are some things to consider.

Establish Your Goals:

Power: How much horsepower do you want to make?

- Think in horsepower. The horsepower output is the single most important factor to size a turbo.
- Don't think in boost pressure. Boost is just a number that you will have to run on your engine to make a certain horsepower.
- Can your vehicle (not just the engine, but the entire setup) handle your power target? Think of pistons, connecting rods, head studs, etc.
- Translate your targeted wheel HP into a crankshaft HP. Rule of thumb: add 20%

Intended Usage

- What are you using the vehicle for? Are you targeting peak horsepower or fast boost response?
- The way that you will be using the vehicle dramatically changes the sizing of the turbocharger and intercooler needs.
- Your choice of transmission type and gearing will greatly affect the performance and characteristics of the turbocharger.

Packaging

- Will the turbocharger(s) fit in your vehicle's space constraints?
- Consider using differently sized compressor housings to more easily fit a given location.

Choosing a Turbine Wheel and Housing Combination

- 1. Ignore the compressor side for a moment:** Start with the turbine side.
- 2. Turbine Wheel:** Choose the smallest wheel diameter that meets the target engine horsepower level. Turbine wheel HP limits are located on page 7. If you choose a larger wheel, you will jeopardize boost response.
- 3. Turbine Housing:** Fine tune the turbine side by choosing an appropriate housing. Boost response/spool-up time is affected by both turbine wheel diameter and turbine housing A/R. The A/R sizing can be used as a tool to fine tune the response range in the RPM band. The smaller the A/R, the faster the turbocharger will be able to spool up. Similarly, choose a larger housing and the setup will respond more slowly to throttle changes, but make more top end power.



Boost Response or Maximum Horsepower

This is the most important and most discussed question when configuring your turbocharger. The basic dilemma is: Do you want to maximize the horsepower output of the engine at a very small rpm range and accept a slower boost response at lower rpms, or do you need immediate throttle response throughout the rpm range and are not too concerned with the maximum horsepower number?

In street/autocross/drift applications, a faster response is generally preferred, and a smaller turbocharger achieves exactly that. Conversely, dedicated drag racers for example need peak power, not boost response. Therefore larger frame turbochargers are used to maximize horsepower.



A/R Ratio

The A/R number you normally see cast into a turbine housing is basically a description for how “big” a turbine housing is. The larger the number, the bigger the housing. As the volume decreases in the volute of the housing, the exhaust gas is able to maintain velocity and a high energy level therefore increasing turbine wheel speed. But if the turbine housing A/R is too small, it can become a choke point, limiting the efficiency of the system by increasing backpressure and preventing total horsepower capability.

For racing applications it is often critical to maximize the turbine housing A/R as much as possible to keep backpressure low and efficiency high while still providing the necessary response time, but some backpressure can be a good thing for street driving use as the pressure differential helps with turbine wheel speed and transient boost response.

While turbine housing A/Rs have a huge impact on the overall turbocharger efficiency, compressor housings do not have the same effect. That is why compressor housings hardly ever come with a range of different A/Rs.

We carry a wide range of different A/R ratio turbine housings for all Turbonetics turbos, making it easy to fine tune your turbo setup by simply changing the turbine housing.



Notice how tight the throat of the volute is on the right turbine housing.

The smaller A/R dramatically improves turbine response time.

Twin Turbo or Single Turbo?

In general, a big single turbo is going to work better than two smaller turbos because bigger are usually more efficient than smaller ones. On a small V-engine, the exhaust manifolding can be tricky. If a single turbo can be packaged neatly without any serious compromises, then that is the way to go. Only one set of oil lines, only one air inlet and exhaust outlet routing required.

However, there are times when twins have an advantage. Because twins will be smaller, they may package better in certain engine bays (especially V-engines) with shorter exhaust manifold piping. Some engine configurations (like an inline 6) lend themselves to a twin set up due to the firing order and even exhaust pulses. The downsides are the multiple oil lines, inlet plumbing, exhaust plumbing, and the cost of two turbos and wastegates.





Turbonetics

A Wabtec company

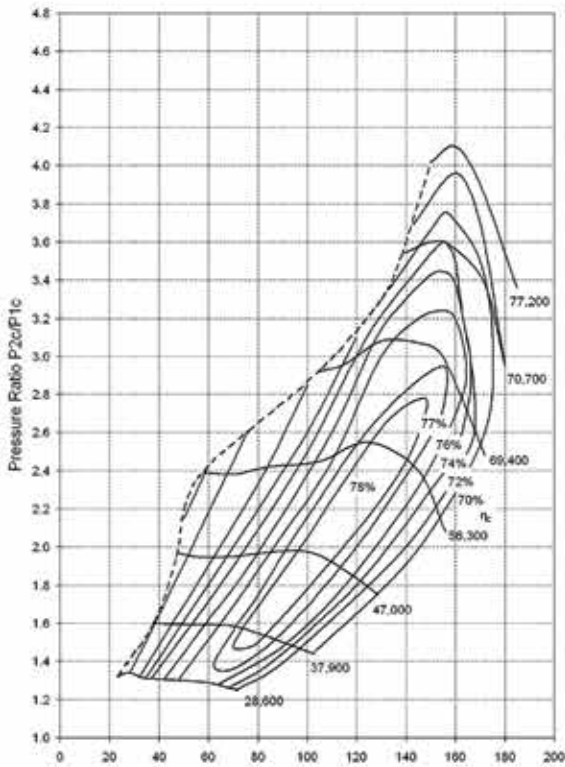

$$\text{CORRECTED MASS AIR FLOW (LB./MIN)} = W \sqrt{T1c/545} / (P1c/28.4)$$

MAP: Manifold Pressure in absolute (subtract 14.7 to get to the actual pressure)

- W:** Airflow (lb/min), this is determined by your horsepower goal
- R:** Gas constant. 639.6
- T:** Intake Manifold Pressure in F.
Ranges from ~100-130F for intercooled setups
- VE:** Volumetric efficiency; use 0.95-0.99 for peak efficiency for modern 4 valve engines
- N:** Engine RPM
- V:** Engine displacement in cubic inches.
Multiply liters by 61.02 to get to cubic inches

Let's calculate the manifold pressure for an intercooled 2 liter engine, max RPM 6000, goal 380HP.

- W:** 380/10 = 38lbs/min
- T:** Assume a very efficient Spearco intercooler, 100 degrees F
- VE:** Assume 0.98
- N:** 6000
- V:** 2l * 61.02 = 122.04 cubic inches

How to Read a Compressor Map

One of the most important aspects to a well designed turbo system is choosing the right compressor and turbine wheel correctly. When the right wheels are selected you can be confident that the turbocharger is going to perform exactly as it should without complications from surge, excessive lag or overspeed. We have already discussed turbine wheel selection in the previous section. Let's look at the compressor wheel next. Using a gasoline engine example, let's look at how to read compressor maps.

Power produced by any gasoline-fueled engine is a function of how much air flows into the engine, regardless of whether it is naturally aspirated, supercharged or turbocharged. Air flow is shown on the x-axis marked as "Corrected Mass Air Flow" and is measured in lb/min. It takes approximately 1 lb of air per minute to make 10 HP. If an engine makes 500 HP then it flows 50 lbs of air per minute.

Now let's look at the pressure ratio, the y-axis on the compressor map marked as "Pressure Ratio" on the left hand side. Pressure ratio is defined as absolute compressor discharge pressure P2, divided by the absolute inlet (ambient) pressure. The term "absolute" means that you have to account for the ambient pressure of 14.7 psi. So let's say you are running at 15 psi of boost: (15 psi + 14.7 psi) / 14.7 psi = 2.02 pressure ratio.

But how do you know where on the compressor map your engine operates? Well, for that you have to know a little more and do some math. While this can get complicated quickly, we will try to explain on a simplified example how to use compressor maps to find out where your engine is at.

Compressor Map Formula

Any operating point can be calculated using the following formula:

$$\text{MAP} = \frac{W \times R \times (460 + T)}{VE \times 0.5 + N + V}$$

Plugged into the above formula results in MAP = 24.39 psi. Adjust for ambient pressure (subtract 14.7 psi) results in 9.69 psi of required boost or a pressure ratio of 1.66. Note that for this calculation we are making a lot of assumption, including no loss from the intake, operating at sea level, no interaction with the turbine side and so on. So your real manifold pressure will be somewhat different from this number.

In practice, you would most likely calculate the maximum the engine will be able to make, so a basic compressor choice could be made based on this single point alone. To get it perfect, you have to calculate a lot of points throughout the entire RPM range and change the parameters for each point accordingly. Remember, our calculation here is a very simplified example. To make sure you do choose the right turbo, contact your Turbonetics dealer.

Pressure Ratio PC/P1C



Turbonetics

A *Wabtec* company

The most important number to start with is knowing how much horsepower you need. Boost pressure is what you will have to run to achieve your power target and depends on the size and efficiency of your engine. Notice how 45 psi of boost makes no more power than 30 psi using this wheel/housing combination. If the engine has a small displacement or is very inefficient it may result in being forced to run more boost to make the same power a larger, more efficient engine could at lower boost pressures.

For more compressor maps information, visit our website www.turboneticsinc.com

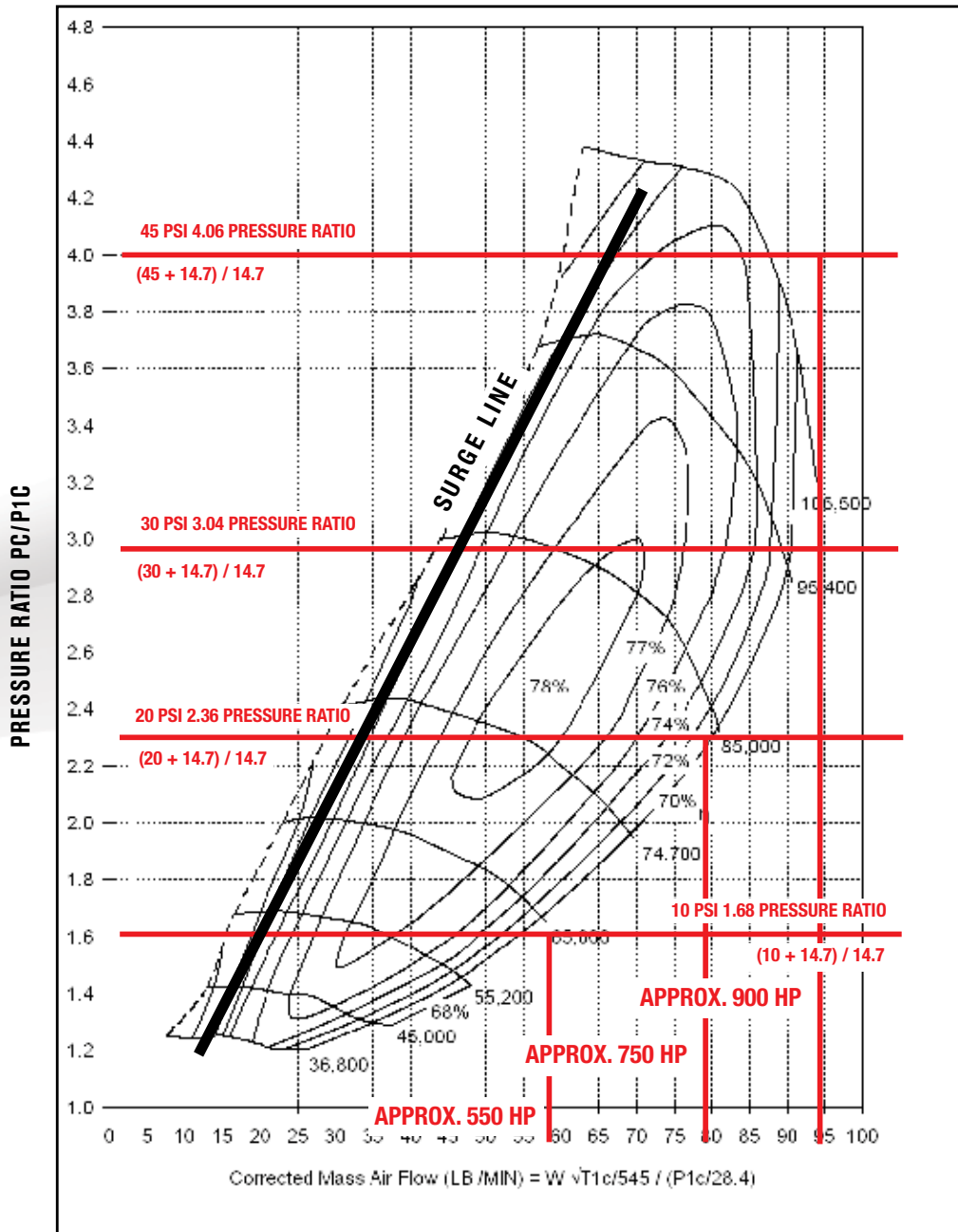

$$\text{Corrected Mass Air Flow (LB/MIN)} = W \sqrt{T1c/545} / (P1c/28.4)$$





Turbonetics

A Wabtec company



Industrial / Military / Unmanned Solutions

TURBOS

Forged from the extreme conditions of racing environments and used in some of the most demanding industrial/military environments on the planet, our patented bearing technology has revolutionized turbocharger standards of durability and performance. Turbonetics offers a patented Angular-Contact Ceramic Ball Bearing design. This Turbonetics exclusive design is made with almost indestructible silicone-nitride ceramic balls. A conventional unit has a capacity of 60-80 lbs. of dynamic thrust load. The patented Turbonetics' design can withstand anywhere from 1000 to 2500 lbs. of loading depending on the frame size.

The "angular-contact" feature offers extreme strength because it is used as the loading surface instead of softer, weaker parts in standard units. What does this mean? It means the turbocharger is exceptionally durable in high-pressure ratios, is not susceptible to thrust failures common with standard bearing turbos, and will provide fantastic transient response.

Turbonetics' patented High Pressure Ratio/High Efficiency aerodynamics allows for reliability and performance regardless of your boost pressure requirements. Our high-pressure ratio turbo designs are being utilized today for unmanned aircraft in extremely demanding applications. In alternative fuel industrial applications this advanced technology allows for greater efficiency and therefore better emissions compliance.

Along with our full engineering staff ready to help you match turbochargers for your specific requirements, Turbonetics utilizes compressor and turbine component balancing as well as multiple high-speed VSR (Vibration Sorting Rig) Core Balancing Machines. "Core balancing" ensures a turbocharger rotor assembly is balanced in its final assembled condition, at close to normal operational speeds. This process minimizes bearing loads and vibration, producing a quiet and reliable turbocharger with a long service life. Turbonetics can address your specific application needs with a wide variety of standard product or ground up custom designs. Please call our sales staff to discuss how we can help you today.





Industrial / Military / Unmanned Solutions

HEAT EXCHANGERS

Conventional intercooler cores are thin-walled, extruded aluminum tubes that are not designed to handle extreme boost pressures and limit cooling performance because of their narrow width. Turbonetics' W.A.V.E. Technology Cores (Wide Area Vane Effectiveness) utilize the latest design advances in strength and durability and maximize cooling effectiveness through a greater surface area. In addition to our selection of cast-aluminum manifolds which are used on a variety of cores, it is also possible to fabricate special manifolds from sheet and v-channel aluminum for special applications to fit all intercooler installation requirements and aid you in initial fit and function.

Turbonetics can also fabricate complete assemblies to our customer's specifications or sketches as well as offering complete engineering assistance for intercooler design and applications. Specializing in both air-to-air and air-to-liquid type heat exchangers, our engineering staff is ready to provide solutions to cool your forced induction applications. Whether you need a stronger core design to withstand higher boost pressures, an intercooler assembly to increase fuel efficiency, water/radiator solutions, engine/transmission oil cooler or a unique high performance application focusing on horsepower capabilities, Turbonetics has what you are looking for.

- W.A.V.E. Technology cores provide greater efficiency.
Bar & Plate design for rugged conditions and high boost pressures
- Core construction process capable of withstanding high pressures (100+ psi)
- Increase fuel economy by providing a denser air intake charge
- Air to air and air to liquid internal and external vane designs help to lower inlet temperatures



Turbonetics

A **Wabtec** company



Industrial / Military / Unmanned Solutions

CONTROLS & VALVES

All of Turbonetics' high performance wastegates and valves are designed and tested to control boost and flow large volumes of exhaust gases. Turbonetics' wastegates feature investment cast stainless steel bases, precision machined parts, high temperature resistant diaphragms, computer modeled and flow tested inconel valve designs and v-band connections. These wastegates perform under pressure and handle high EGTs (Exhaust Gas Temperatures) to protect your engine from over boosting while efficiently evacuating hot gases to lower back pressure when running under wide open throttle.

All of our by-pass valves are engineered to efficiently alleviate boost pressure contained within the induction system by venting or re-routing air pressure to prevent surging and unnecessary wear on the turbocharger. Our wastegate and by-pass valve lineup is able to be applied on low displacement (< 1 liter), low boost (< 5 psi) applications all the way up to large 10+ liter engines running 100+ psi in compound boost setups.

From automotive gasoline to natural gas powered stationary engines, Turbonetics has your boost control needs covered. Turbonetics industrial products are built to last. Offered as original equipment on large displacement natural gas and diesel power plants, our regulators endure extreme hours and conditions to control boost year after year. Made in a variety of different configurations for numerous types of industrial applications, these valves use the latest technology and material specifications to deliver on strict OEM requirements.

- Multiple configurations available for a wide variety of engine types and sizes, including diesel and natural gas
- Computer aided designs allow maximum flow and precise boost control
- Patented valve designs aid in reducing backpressure to optimize horsepower capabilities
- High strength components allow extreme use and ensure long life

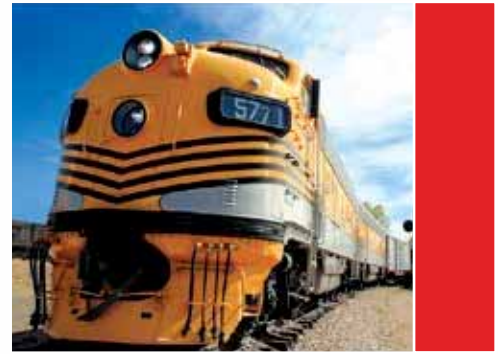



TNX 20 SERIES

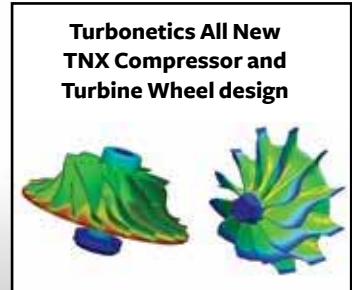

WITH PATENTED CERAMIC BALL BEARING TECHNOLOGY

TNX 20 SERIES TURBOCHARGERS

For the first time Turbonetics is offering a T2 based turbocharger to the public. The TNX 20 is small in stature but packs serious punching power. The 20 will support up to 450hp in a single turbo application.

Turbonetics TNX Compressor and Turbine Stages are designed using advanced Computational Fluid Dynamics (CFD) and Finite Element Analysis (FEA) tools to optimize performance and durability. This ensures high efficiency over a broad operating range and reliability under the most demanding conditions.

Our Compressor Wheels and Housings are designed for high air flow and wide operating range to maximize horsepower and drivability. Our turbines are designed for low inertia and high exhaust temperatures for fast boost response and longevity under extreme operation.

TNX Series Turbocharger Features:

- Brand new patent pending floating dual ceramic ball bearing design
- Dual oil seals on compressor and turbine side
- Compact lightweight design
- Internally wastegated
- Available in standard bearing or dual ball bearing

Application	HP	Comp. Housing	Comp Wheels Major/Inducer Dia.	Turbine Wheel Major/Inducer Dia.	P/N Std Bearing	P/N Dual BB
TNX-20/44	300	T3	57/44mm	54/43mm	11814	11815-BB
TNX-20/48	400	T4B	62/48mm	54/43mm	11897	11897-BB
TNX-20/52	450	T4B	67/52mm	54/43mm	11815	11815-BB

Turbo sold as a super core (minus turbine housing)

Please select turbine housing option below.

Turbine Inlet Style Internal Gate	P/N Turbine Inlet
TNX-20 T25 .65 A/R	11821-1
TNX-20 T25 .85 A/R	11822-1

MATRIX CHART					
2.5 LITER ENGINE DISPLACEMENT			TNX-20/52 0.85 A/R 11815		
2.0 LITER ENGINE DISPLACEMENT			TNX-20/48 0.65 A/R 11897	TNX-20/52 0.85 A/R 11815	TNX-20/52 0.85 A/R 11815
1.5 LITER ENGINE DISPLACEMENT	TNX-20/44 0.65 A/R 11814	TNX-20/44 0.65 A/R 11814	TNX-20/44 0.85 A/R 11814	TNX-20/44 0.85 A/R 11814	TNX-20/44 0.85 A/R 11814
1.0 LITER ENGINE DISPLACEMENT	TNX-20/44 0.65 A/R 11814	TNX-20/44 0.65 A/R 11814	TNX-20/44 0.65 A/R 11814	TNX-20/44 0.65 A/R 11814	
	100 HP	150 HP	200 HP	250 HP	300 HP



TNX 30 SERIES



WITH PATENTED CERAMIC BALL BEARING TECHNOLOGY

TNX 30 SERIES TURBOCHARGERS

The TNX 30 is our next generation T3/T4E turbocharger and will replace our current legacy 40 trim through 60 trim turbos. These sizes will support up to 600hp in a single turbo application."

Turbonetics TNX Compressor and Turbine Stages are designed using advanced Computational Fluid Dynamics (CFD) and Finite Element Analysis (FEA) tools to optimize performance and durability. This ensures high efficiency over a broad operating range and reliability under the most demanding conditions.

Our Compressor Wheels and Housings are designed for high air flow and wide operating range to maximize horsepower and drivability. Our turbines are designed for low inertia and high exhaust temperatures for fast boost response and longevity under extreme operation.

TNX Series Turbocharger Features:

- Brand new patent pending floating dual ceramic ball bearing design
- Dual oil seals on compressor and turbine side
- Compact lightweight design
- Externally gated
- Available in standard bearing or dual ball bearing

Application	HP	Comp. Housing Major/Inducer Dia.	Comp Wheels Major/Inducer Dia.	Turbine Wheel Std Bearing	P/N Standard BB	P/N Dual BB
TNX-30/48	400	T04B	62/48mm	60/48mm	11819	11819-BB
TNX-30/52	450	T04B	67/52mm	60/48mm	11899	11899-BB
TNX-30/56	500	T04E	72/56mm	60/48mm	11816	11816-BB
TNX-30/60	650	T04E	78/60mm	60/48mm	11817	11817-BB

Turbo sold as a super core (minus turbine housing)
Please select turbine housing option below.

Turbine Inlet Style Internal Gate	P/N Turbine Inlet
TNX-30 T3 .65 A/R	11823
TNX-30 T3 .85 A/R	11824

MATRIX CHART					
4.0 LITER ENGINE DISPLACEMENT	TNX-30/60 0.85 A/R 11817	TNX-30/60 0.85 A/R 11817	TNX-30/60 0.85 A/R 11817	TNX-30/60 0.85 A/R 11817	TNX-30/60 0.85 A/R 11817
3.5 LITER ENGINE DISPLACEMENT	TNX-30/60 0.85 A/R 11817	TNX-30/60 0.85 A/R 11817	TNX-30/60 0.85 A/R 11817	TNX-30/60 0.85 A/R 11817	TNX-30/60 0.85 A/R 11817
3.0 LITER ENGINE DISPLACEMENT	TNX-30/56 0.85 A/R 11816	TNX-30/56 0.85 A/R 11816	TNX-30/56 0.85 A/R 11816	TNX-30/60 0.85 A/R 11817	TNX-30/60 0.85 A/R 11817
2.5 LITER ENGINE DISPLACEMENT	TNX-30/52 0.85 A/R 11899	TNX-30/56 0.85 A/R 11816	TNX-30/56 0.85 A/R 11816	TNX-30/60 0.85 A/R 11817	TNX-30/60 0.85 A/R 11817
2.0 LITER ENGINE DISPLACEMENT	TNX-30/48 0.85 A/R 11819	TNX-30/48 0.85 A/R 11819	TNX-30/48 0.85 A/R 11819	TNX-30/56 0.85 A/R 11816	TNX-30/56 0.85 A/R 11816
	300 HP	350 HP	400 HP	500 HP	550 HP



Turbonetics

A **Wabtec** company



TNX 40 SERIES

**Turbonetics All New
TNX Compressor and
Turbine Wheel design**

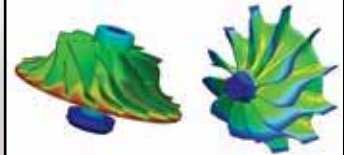

**WITH PATENTED
CERAMIC BALL BEARING
TECHNOLOGY**

TNX 40 SERIES TURBOCHARGERS

The TNX 40 & 45 features a newly designed compressor housing called the TNX D Compressor Housing. The 40 & 45 will replace our current legacy 60 Series turbochargers and support up to 750hp in a single turbo application.”

Turbonetics TNX Compressor and Turbine Stages are designed using advanced Computational Fluid Dynamics (CFD) and Finite Element Analysis (FEA) tools to optimize performance and durability. This ensures high efficiency over a broad operating range and reliability under the most demanding conditions.

Our Compressor Wheels and Housings are designed for high air flow and wide operating range to maximize horsepower and drivability. Our turbines are designed for low inertia and high exhaust temperatures for fast boost response and longevity under extreme operation.

TNX Series Turbocharger Features:

- Brand new patent pending floating dual ceramic ball Bearing design
- Dual oil seals on compressor and turbine side
- Compact lightweight design
- Operating range enhancement ported shroud available on models with TNX D compressor cover designed for strength and performance!
- Available in standard bearing or dual ball bearing

Application	HP	Comp. Housing	Comp Wheels Major/Inducer Dia.	Turbine Wheel Major/Inducer Dia.	P/N Std Bearing	P/N Dual BB
TNX-40/60	750	TNX D COVER	78/60mm	69/55mm	11881	11881-BB
TNX-40/64	800	TNX D COVER	82/64mm	69/55mm	11818	11818-BB
TNX-45/64	850	TNX D COVER	82/64mm	74/58mm	11820	11820-BB
TNX-45/69	900	T-SERIES	88/69mm	74/58mm	11857	11857-BB

Turbo sold as a super core (minus turbine housing)

Please select turbine housing option below.

Turbine Inlet Style Internal Gate	P/N Turbine Inlet
TNX-40 T3 .65 A/R	11825
TNX-40 T3 .85 A/R	11826
TNX-45 T3 .65 A/R	11827
TNX-45 T3 .85 A/R	11828

MATRIX CHART					
3.5 LITER ENGINE DISPLACEMENT	TNX-45/64 0.85 A/R 11820	TNX-45/64 0.85 A/R 11820	TNX-45/64 0.85 A/R 11820	TNX-45/69 0.85 A/R 11857	
3.0 LITER ENGINE DISPLACEMENT	TNX-40/60 0.85 A/R 11881	TNX-40/60 0.85 A/R 11881	TNX-45/64 0.85 A/R 11820	TNX-45/64 0.85 A/R 11820	TNX-45/69 0.85 A/R 11857
2.5 LITER ENGINE DISPLACEMENT	TNX-40/60 0.85 A/R 11881	TNX-40/60 0.85 A/R 11881	TNX-45/64 0.85 A/R 11820	TNX-45/64 0.85 A/R 11820	TNX-45/69 0.85 A/R 11857
2.0 LITER ENGINE DISPLACEMENT	TNX-40/60 0.85 A/R 11881	TNX-40/60 0.85 A/R 11881	TNX-40/60 0.85 A/R 11881	TNX-45/64 0.85 A/R 11820	
	550 HP	600 HP	700 HP	800 HP	900 HP



Turbonetics

A **Wabtec** company



Aerodynamics is what separates the GT-K turbo line from the competition.



GT-K BILLET BY TURBONETICS

HPC BILLET GT-K TURBOCHARGERS



Following the previous successful GT-K turbos is our latest revision to this line of turbos. Our engineers have been hard at work for the last few years trying to make our popular GT-K line of turbos even better. The new Billet GT-K line of turbos features all new Billet Compressor wheels which will flow more air than any of our previous GT-K models.

The GT-K series, Turbonetics' premium turbochargers covering the 325 to 1050 horsepower range, is expanding its lineup with HPC forged billet aluminum compressor wheels in the newly developed GT-K 600, 700, 750, 850 and 1050 turbochargers. A further development over the HP compressor wheels, the HPC (High Pressure Competition) compressor wheels provide even greater efficiency and airflow. To withstand the extreme pressures, HPC compressor wheels are machined from forged blanks instead of standard bar stock. Wheels machined from forged blanks have stronger blades and wheel hubs, allowing maximum airflow while minimizing rotating mass.

In addition to Turbonetics' HPC forged billet compressor wheels, the newly developed GT-K 600, 700, 750, 850 and 1050 turbochargers feature brushed satin finish on the compressor housing and black ceramic coated turbine housing which not only helps with heat containment, but provides a distinguished look. The brushed satin finish is an extremely durable finish that is scratch and chip resistant. The black ceramic coating on the turbine housing further differentiates the Billet GT-K series from the lineup.

As with previous GT-K turbochargers, the patented ceramic ball bearing center housing rotating assembly (CHRA) is standard on all GT-K turbochargers. Turbonetics' ceramic ball bearing design offers 50 times greater thrust capacity and is more resilient under high temperature shut-downs than conventional journal bearing design. The patented "angular-contact" design offers extreme strength because it is used as the thrust-loading surface. This exclusive technology allows ultra fast transient response and extremely quick spooling of the turbocharger. With Turbonetics' GT-K turbochargers, you will build boost faster at the line and reach targeted boost pressure sooner in the RPM band.

TURBO	HP RATING	COMPRESSOR WHEEL	COMPRESSOR HOUSING STYLE	COMP. HOUSING INLET/OUTLET	TURBINE WHEEL	TURBINE HOUSING STYLE	TURBINE HOUSING INLET/OUTLET	TURBO W/AIR COOLED CENTER HOUSING	TURBO W/WATER COOLED CENTER HOUSING
GT-K 850	850	C-72	T Series	4.0" / 2.5"	F1-68	T4 .81 A/R	4-bolt/4" V-band	11585	11586
GT-K 1050	1050	C-75	T Series	4.0" / 2.5"	F1-68	T4 .96 A/R	4-bolt/4" V-band	11593	11594

*Description name also denotes turbo crankshaft horsepower rating.





**Exceptional Spool-Up
and Boost Response**



HURRICANE SERIES TURBOCHARGERS

Based on the T-Series design, the Hurricane Series delivers exceptional spool-up and boost response with the optional Turbonetics patented Ceramic Ball Bearing (CBB) and high pressure compressor housing combination. It is the perfect choice for smaller displacement engine applications in the 500-800HP range that need to run high boost pressures and other vehicle applications that require smaller turbocharger compressor housings due to engine bay packaging constraints. As the smallest of the mid range turbos, the Hurricane series combines T04 turbines with large HP wheels in smaller 60-Series compressor housings.



Turbo	HP Rating	Compressor Wheel	Compressor Housing Style	Compressor Housing Inlet/Outlet	Turbine Wheel	Turbine Housing Style	Turbo Housing Inlet/Outlet	Journal Bearing Part Number	Ball Bearing Part Number
Hurricane 6665-4 "Lety"	500-600	HP-66	60 series	4.0"/2.5" Ported Shroud	F1-65	T4 .81	4-bolt/3" V-band	11226	11226-BB
Hurricane 7268-4 "Sylvia"	600-700	HP-72	60 series	4.0"/2.5" Ported Shroud	F1-68	T4 .81	4-bolt/3" V-band	11533	11533-BB
Hurricane 7668 "Vanessa"	650-750	HP-76	60 series	4.0"/2.5"	F1-68	T4 .96	4-bolt/3" V-band	11534	11534-BB
Hurricane 7868 "Benita"	650-800	HP-78	60 series	4.0"/2.5"	F1-68	T4 .96	4-bolt/3" V-band	11535	11535-BB

*Description name also denotes turbo crankshaft horsepower rating.



Turbonetics

A Wabtec company

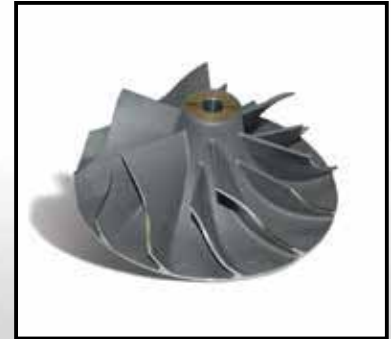

(High Pressure) compressor wheel, specifically designed for max power at over 30psi.

T-SERIES TURBOCHARGERS

T-Series turbos are the true mid range choice for applications from 500 to 950 horsepower. The compressor side consists of a choice of HP wheels (58, 61, 64, 66, 70, 72, 76 and 78mm) that are combined with T-Series housings, nicely matched with one of the many turbine options. Also available in this turbo family are forged billet wheel options (HP-C compressor wheels), that flow even more than cast HP wheels. Check out our website for our latest HP-C options, we are constantly expanding our forged billet wheel selection.

Turbine Wheel		Turbine Housing		
Description	PN (non-BB)	Outlet Style	A/R	PN
F1-68	21486	3" V-band	.58	21592-68
		3" V-band	.68	21593-68
		3" V-band	.81	21594-68
		3" V-band	.96	21595-68
		3" V-band, divided	.58	21596-68
		3" V-band, divided	.70	21597-68
		3" V-band, divided	.84	21598-68
		3" V-band, divided	1.00	21599-68
		3" V-band, divided	1.15	21600-68
F1-75	22323-BB	3" V-band	.96	22325-096
		3" V-band	1.15	22325-115

Compressor Wheel		Housing - polished, 3" outlet	
Description	PN	Inlet Size	PN
HPC-72	22347	4.00"	22350-2
HPC-75	22339	4.00"	21393

Center Housing Options:

AIR COOLED OR WATER COOLED
JOURNAL BEARING OR BALL BEARING

*Description names also denotes turbine exducer diameter in mm.

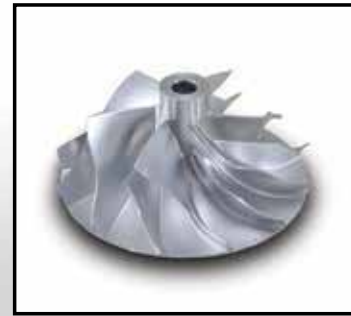

HPC billet compressor wheel options for high airflow applications



***Comes Standard with Turbo Speed Sensor ports on bearing housing**

MID-FRAME TURBOCHARGERS

The largest series within the mid range turbochargers, the mid frame compressor side is designed for H72, C75, H76, C79, H78, C83mm HP wheels and billet HP-C compressor wheels. The turbine side is one size up from the To4, using F1-75 or 82 turbine wheels. For ease of installation and to integrate the Mid-Frame turbo with existing hardware, we maintained the To4 inlet flange and use a 4" outlet on the turbine housing. This combination supports 900 up to 1500 horsepower, the most you can get from a To4 flange, and features Turbonetics' Ceramic Ball Bearing system as standard.

Turbine Wheel Description	Turbine Housing		
	Outlet Style	A/R	PN
F1-75	Mid-Frame	1.00	21404
	Mid-Frame	1.14	21365
	Mid-Frame	1.27	21366
F1-82	Mid-Frame	1.14	22450

*Description names also denotes turbine exducer diameter in mm.

Compressor Wheel		Housing - polished, 3" outlet	
Description	PN	Inlet Size	PN
HP-72	21849	4.50"	21401
HP-76	21419	4.50"	21411
HP-78	21355	4.50"	21395
HPC-72	22348	4.50"	22351-2
HPC-75	22340	4.50"	22343-2
EF5-C83	22454	4.50"	22455
Y2K88	21970	4.50"	21829-1



Turbonetics

A Wabtec company



***Comes Standard with Turbo Speed Sensor ports on bearing housing**

Y2K / SUPER THUMPER TURBOCHARGER

As the largest Turbocharger series, the Y2K / THUMPER Series includes everything with 80mm and larger compressor wheels for applications between 900 and 2400 HP. With large gains in efficiency and air flow in this size range, we strongly recommend using forged billet HPC wheels for all serious race engines. Y2K/THUMPER turbos come standard with Ceramic Ball Bearing systems, ASME bell compressor inlet and 4.5" V-band turbine outlet, these turbos are ready to deliver huge horsepower and big boost – exactly what extreme race applications need.

For those still needing more, our Thumper with 115mm forged billet compressor wheels can deliver 2500+ horsepower. To withstand these extreme conditions, Turbonetics' engineers came up with a monster of a turbo:

- Hex-Lock compressor wheel to prevent wheel slippage
- Oversized Ceramic Ball Bearing system capable of 2600+lbs of thrust
- 4.5" F1 blade design turbine wheel options
- Custom matched, designed and built for your application - Contact us for more information

Turbine Wheel Description	Turbine Housing		
	Style	A/R	PN
F1-89	Y2K	0.96	21784
		1.08	21785
		1.23	21786
		1.39	21787
F1-101	Y2K	1.23	21856
		1.39	21857
F1-106	Thumper	1.00	21863
		1.14	21864
		1.32	21865
		1.50	21866
F1-112	Thumper	1.00	21867
		1.14	21870
		1.32	21868
		1.50	21869

Compressor Wheel		Housing - polished, 3" outlet	
Description	PN	Inlet Size	PN
HP-80	21356	4.50"	21396
HP-88	22329	4.50"	21399
HP-91	21361	4.50"	21403
HP-91	30721	5.50"	20735
HP-94	21997	5.50"	21998
HP-98	30895	5.50"	21006
HP-101	30728	5.50"	20738
HP-106	30649	5.50"	20737
HPC-88	22169	4.50"	22327-2
HPC-91	22171	5.50"	20735
HPC-115	21513	5.50"	21514

*Description names also denotes turbine exducer diameter in mm.



TURBINE OPTIONS

Description	PN	Turbine Wheel			
		Inlet	Outlet Style	A/R	PN
F1-68	21486	T3 4-bolt	V-band 3.0"	.65	22054-68
		T3 4-bolt	V-band 3.0"	.85	22055-68
		T4 4-bolt	T4 3" V-band	.58	21592-68
		T4 4-bolt	Counterbore outlet	.58	21712-68
		T4 4-bolt	T4 3" V-band	.68	21593-68
		T4 4-bolt	Counterbore outlet	.68	21713-68
		T4 4-bolt	T4 3" V-band	.81	21594-68
		T4 4-bolt	Counterbore outlet	.81	21714-68
		T4 4-bolt	T4 3" V-band	.96	21595-68
		T4 4-bolt	Counterbore outlet	.96	21715-68
		T4 4-bolt	T4 3" V-band, divided	.58	21596-68
		T4 4-bolt	T4 3" V-band, divided	.84	21598-68
		T4 4-bolt	Counterbore outlet	.84	21718-68
		T4 4-bolt	T4 3" V-band, divided	1.00	21599-68
		T4 4-bolt	Counterbore outlet	1.00	21719-68
		T4 4-bolt	T4 3" V-band, divided	1.15	21600-68
		T4 4-bolt	Counterbore outlet	1.15	21720-68

Description	PN	Turbine Wheel			
		Inlet	Outlet Style	A/R	PN
F1-75		T4 4-bolt	3" V-band	.96	22325-096
		T4 4-bolt	3" V-band	1.15	22325-115
		T4 4-bolt	4.5" V-band	1.00	21404
		T4 4-bolt	4.5" V-band	1.14	21365
		T4 4-bolt	4.5" V-band	1.27	21366N
		T4 4-bolt	4.5" V-band	1.27	21366N
F1-89		T6 4-bolt	5.00" V-band	.96	21784
		T6 4-bolt	5.00" V-band	1.08	21785
		T6 4-bolt	5.00" V-band	1.23	21786
		T6 4-bolt	5.00" V-band	1.39	21787
F1-101		T6 4-bolt	5.00" V-band	1.23	21856
		T6 4-bolt	5.00" V-band	1.39	21857
F1-106		T6 4-bolt	5.00" V-band	1.00	21863
		T6 4-bolt	5.00" V-band	1.14	21864
		T6 4-bolt	5.00" V-band	1.32	21865
		T6 4-bolt	5.00" V-band	1.5	21866
F1-112		T6 4-bolt	5.00" V-band	1.00	21867
		T6 4-bolt	5.00" V-band	1.14	21870
		T6 4-bolt	5.00" V-band	1.32	21868
		T6 4-bolt	5.00" V-band	1.50	21869



INTERNALLY WASTEGATED TURBINE HOUSINGS



**More Applications
Coming Soon!**

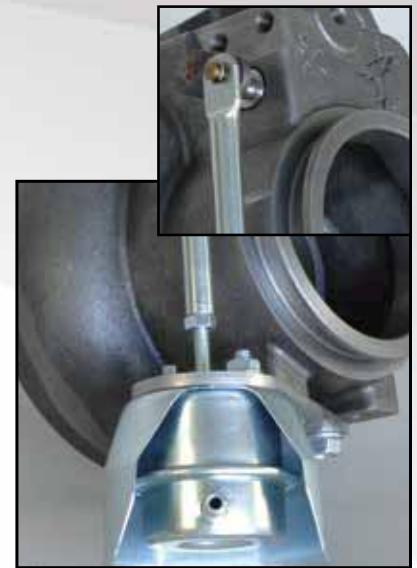

T3 & T4 INTERNALLY GATED HOUSINGS



Internally gated turbine housings are now available in popular T3 or T4 flanges. These turbine housings come with 7psi actuators and features a 3.5" turbine discharge. The T3 version will be available in .65 or .85 a/r's and will be contoured to mate with our TNX 30 or 40 turbos. The T4 version will be available in .90 or 1.05 a/r's and will be contoured for our F1-62, 65 and 68 turbine wheels. More options will be available in the near future. Please see our website for the latest offerings.

T3 Internally Gated Turbine Housings		3.5" V-band Discharge	
Description	A/R	PN	
TNX 30 (T01-48)	.65	22580-1	
TNX 30 (T01-48)	.85	22581-1	
TNX 40 (T01-55)	.65	22580-3	
TNX 40 (T01-55)	.85	22581-3	

T4 Internally Gated Turbine Housings		3.5" V-band Discharge	
Description	A/R	PN	
F1-62	.90	22402-62	
F1-65	.90	22402-65	
F1-68	.90	22402-68	
F1-62	1.05	22403-62	
F1-65	1.05	22403-65	
F1-68	1.05	22403-68	





Turbonetics

A **Wabtec** company



T3



T04B



T04E



TNX D COVER



T-SERIES

Ported shroud shown



MID FRAME & Y2K 80-88



THUMPER 91-115

WHEEL DIMENSIONS AND TRIM



The most important dimensions when choosing a turbocharger are the compressor wheel inducer and the turbine wheel exducer diameters. In addition, the ratio of the compressor wheel inducer to major diameter also affects the turbocharger performance drastically. The ratio of the inducer area divided by the major area is often called “trim”. Generally, a higher trim number wheel means more airflow, while a smaller trim results in faster spoolup.

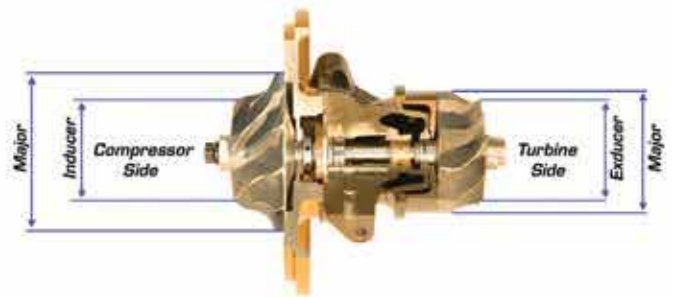



Turbonetics

A Wabtec company

TURBINE HOUSING FLANGES AND GASKETS

Turbonetics turbo accessories make turbo installation a breeze. We have a wide selection of standard and stainless steel flanges, that fit a wide range of industry-standard connection types and turbochargers.



T3 V-Band IN / OUT		
Description	IN/OUT	PN
Flanges	OUTLET	31356
	INLET	31355
Clamps	OUTLET	30242
	INLET	30624

T3 TURBINE HOUSING FLANGES				
SIZE	DRILLED	STAINLESS STEEL	TRAPPED M10	STAINLESS STEEL GASKET
T3 inlet 4bolt		20365S		30263
T3 inlet 5bolt	20367			
T3 discharge 4bolt	21418			

T4 TURBINE HOUSING FLANGES				
SIZE	DRILLED	STAINLESS STEEL	TRAPPED M10	STAINLESS STEEL GASKET
T4 inlet flange, 4bolt	21102		21103	30143
T4 inlet flange, 4bolt, divided	n/a	n/a	n/a	30143-DIV
T4 inlet flange, 4 bolt, 2.25" hole				use 30143
T4 discharge flange, 4 bolt, 2.25" hole				30142S
T4 discharge flange, 4 bolt, 3" hole				30142S

T6/Y2K TURBINE HOUSING FLANGES				
SIZE	DRILLED	STAINLESS STEEL	TRAPPED M10	STAINLESS STEEL GASKET
T6 Y2K 80 through Thumper 106 inlet				included in 10794 kit



PN: 31040 T3
5-Bolt Discharge



PN: 20163



PN: 30223 T4 Tangential

TURBINE HOUSING HEATSHIELDS

Improve performance and protect components in your engine bay at the same time with Turbonetics' heatshields. Made from aerospace grade material, and installing in minutes, these heat shields keep the exhaust gas heat where it belongs: Inside the turbine housing. The more energy you can keep directed at the turbine wheel the better the performance of the turbo. We use ceramic fiber wrapped with corrugated aluminum foil to keep the inside of your turbo hot, and the outside cool.

Heatshields	
PN	Description
31171	Heatshield - T3 turbine housing, fabric
31040	Heatshield - T3 5 bolt turbine housing, flexible
31172	Heatshield - T4 tangential turbine housing, fabric
30223	Heatshield - T4 tangential turbine housing, hard shell
20163	Heatshield sheet - 6" x 14"



TURBINE HOUSING V-BANDS

V-bands are quickly becoming the number one choice in making turbine housing connections. For good reasons: They allow fast and easy turbo installation and removal, do not require a gasket, and can be oriented in any rotation.

T3 V-Band IN / OUT		
Description	IN/OUT	PN
Flanges	OUTLET	31356
	INLET	31355
Clamps	OUTLET	30242
	INLET	30624

V-Band Adapter	
PN	Description
20760	V-band adapter - 3" to 3.5"
20761	V-band adapter - 3" to 4"

T4 TURBINE HOUSING FLANGES					
SIZE	TURBINE HOUSING WELD FLANGE	TUBE WELD FLANGE	TUBE WELD FLANGE STAINLESS STEEL	V-BAND CLAMP	USE ON TURBINE HOUSING
2.5"	30230	30231	30231-S	31096	T3
3"	20244	22416-2	22416-2*	30242	T3, T4, GT-K, Hurrincance, TN
3.5"		22417-2		30408	
4"	20533	30409*	30409-S	30410	T-series
Y2K / Thumper	N/A	30419	30419-S	31390	Y2K / Thumper
4"	20534	30409	30409-S	39410	Mid Frame

* Formally 30241, 22416-2 is the same part number in stainless

OIL FLANGES

OIL FLANGES			
DESCRIPTION	PN	FITS TURBO FAMILIES	GASKETS
Oil drain flange	20259	T3, T3/T4	30141
Oil drain flange, billet	20258	T3, T3/T4	30141
Oil drain flange	21521	Mid Frame, Y2K / Thumper	
Oil inlet flange		Mid Frame, Y2K / Thumper	
Gasket kit (oil inlet & drain, turbine inlet)	10794	TNX91 through Y2K / Thumper	

Complete a clean and durable installation with genuine Turbonetics oil line gaskets and flanges



PN: 22490-1



PN: 30141



PN: 20259



PN: 21521

OIL GASKETS

OIL Gaskets			
FITTINGS	ORIENTATION	PN	FITS
3/8" NPT x 5/8" hose	straight		watercooled center housings with 3/8 NPT fitting
1/2" NPT x 5/8" hose	straight	30244	oil drain, all turbos
1/2" NPT x 5/8" hose	45°		oil drain, all turbos
1/2" NPT x 5/8" hose	90°		oil drain, all turbos
1/8" NPT x 5/32" hose	straight	30306	Vacuum hose 30542-BK
1/8" NPT x 5/32" hose	90°		Vacuum hose 30542-BK
1/8" NPT x 1/4" hose	90°		Vacuum hose 30543-BK



PN: 10794

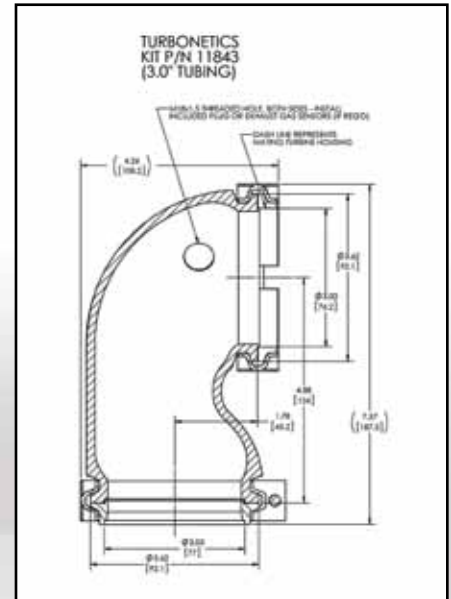

3" KIT PN: 11843

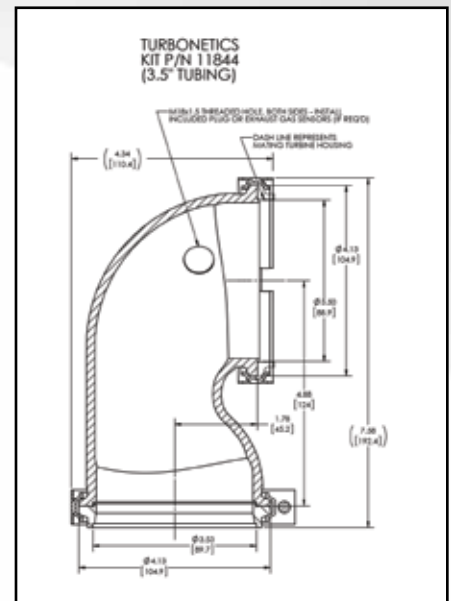

3.5" KIT PN: 11844

TURBONETICS TIGHT RADIUS EXHAUST ELBOW

Turbonetics Tight Radius Exhaust Elbow was designed for cramped engine bays. Designed to maximize the flow and performance. Mates with any Turbonetics existing turbine housings with a 3.0" or 3.5" v-band discharge.

Turbonetics Tight Radius Exhaust Elbow Features:

- Made from ductile iron
- Mating v-band flanges & clamps are made of stainless.
- Designed to mate to any Turbonetics existing turbine housings with a 3.0" or 3.5" v-band discharge
- Housing comes with (2) M18x1.5 plugs, that can be removed, for user-installed exhaust gas sensors
- Tight-radius elbow, specifically designed for cramped engine bay installations
- Each kit contains (1) housing, (1) outlet v-band flange, (2) v-band clamps, (2) M18 plugs
- CFD designed to maximize flow and performance



ASME COMPRESSOR INLET KITS

Designed to ASME specifications, the compressor Inlet kit allows you to maximize airflow velocity and air volume at the compressor inlet. Manufactured from spun aluminum, the kit comes complete with polished bellow, silicone hose and T-clamps. Adds 2.5" to 3" to the length of the turbo inlet. See page 28 for compressor housing inlet sizes.

COMPRESSOR INLET KITS	
PN	DESCRIPTION
10766	3" Inlet Kit
10767	4" Inlet Kit
20817P	4.5" Inlet Bell
20816P	5.5" Inlet Bell



PLENUMS

Turbonetics pressure plenum features a ball-burnished finish. This low-profile design is great for low clearance hood applications.

Pressure Plenums will fit the standard 5-1/8" carburetor inlet or can be modified to fit 4 barrel EFI throttle bodies.

PLENUMS	
PN	PLENUMS
10351	3" side entry



PN 10351

EXTERNAL WASTEGATES

All of Turbonetics' high performance wastegates are designed and engineered to control boost and flow large amounts of gas volumes, allowing the complete turbo system to be balanced perfectly. All of our wastegates are made from stainless steel bases and high temperature resistant diaphragms to withstand extreme EGTs (Exhaust Gas Temperatures). All external wastegate kits come complete with flanges and clamps, and with an adjustable set screw to fine-tune the valve's response.



**RG-45 Kit
KIT PN 11240**

RG-45 45MM WASTEGATE	
Ancillary Parts for RG-45 45mm Wastegate	PN
Spring Purple 15 PSI	31151-15
Spring Black 11 PSI	31151-11
Spring Green 8 PSI	31151-8
Spring Brown 5 PSI	31151-5
Diaphragm	21648
Weld Flange	21910
Weld Flange Outlet	21911
Valve Seat Clamp In or Out	30626

WASTEGATE KITS			
DESCRIPTION	SIZE	HP RATINGS	PN
Evolution kit	35mm	up to 500HP	10780
RG-45 kit	45mm	up to 750HP	11240



Turbonetics

A Wabtec company

External Wastegates



EVOLUTION KIT
KIT PN 10780

EVOLUTION 35MM WASTEGATE	
Ancillary Parts for Evolution 35mm Wastegate	PN
Flange, drilled	20260
Flange, drilled, stainless steel	20260S
Flange, tapped, 5/16" - 18	20261
Flange, tapped, 5/15" - 18, stainless steel	20261S
Flange, tapped, M8	20981
Replacement Gasket	20142
Spring 9PSI	30778-9
Spring 7PSI	30778-7
Spring 5PSI	30778-5
Diaphragm	20644
Valve Seat	20763





**GODZILLA
KIT PN 10765**

BLOW OFF VALVES

The use of a blow off valve is essential on engines where the throttle is controlled by a butterfly inside the throttle body (basically all engines except diesels). As the throttle is lifted the inertia of the turbo is still producing boost. But with the butterfly closed, the pressured air has nowhere to go and the result is a sudden increase in pressure upstream of the butterfly. This can cause damage to the turbo, intercooler, and ultimately the engine very quickly. A blow off valve releases this pressure spike into the atmosphere before damage is done. A bypass valve is basically the same as a blow off valve. But instead of venting pressure to the outside, the air is routed back into the turbocharger inlet.

BOOST CONTROLLERS

Boost controllers allow increasing boost levels without physically changing your wastegate setting. Turbonetics offers the classic VBC kit for three different boost ratings. All of our kits come with a wide selection of fittings and all necessary hardware.

BOOST CONTROLLER KITS			
BOOST CONTROLLER KITS	PSI RANGE	PN	COMPATIBLE WITH:
Classic VBC	0 to 10	10402-10	all external wastegate, dual port actuators
Classic VBC	0 to 25	10402-25	all external wastegate, dual port actuators
Classic VBC	0 to 50	10402-50	all external wastegate, dual port actuators

"GODZILLA" VALVE ASSEMBLY	
Description	PN
Valve body assembly	N/A
V-band clamp assembly	30422
Valve body O-ring	30467
Base flange fastener	30471
Base flange	20491
Base flange O-ring	30468
Weld flange, steel	20507S
Weld flange, aluminum	20507A
Discharge gasket	20510
Discharge hose adapter	20495
Discharge horn assembly	10692
Discharge fastener	30470
Diaphragm Godzilla	20502



**CLASSIC VBC KIT
EXTERNAL WASTEGATE AND DUAL
PORT ACTUATORS ONLY**



SILICONE CONNECTORS



Getting the boost leak-free from your Turbonetics' turbocharger to the engine is a breeze with our versatile selection of silicone connectors. Made from multi-layer silicone with fiberglass reinforcements, these connectors withstand the highest boost pressures and temperatures.



HUMP NOSE

TRANSITION HOSES (BLACK)	PN
3" to 4"	30502-4

SIZE	3 FT. HOSE (0.188" WALL) BLACK, 30 PSI	COUPLING (0.125" WALL) BACKS	HUMP BLACK
3"	30352-300-BK	30162-4	30435-4
4"		30302-4	

T-BOLT CLAMPS



Much stronger than conventional "worm drive" clamps, these stainless steel T-clamps are 0.75" wide to protect the silicone hoses and include temperatures, pressures and vibration.



NEWGEN 51MM WASTEGATE		
Hose ID	Clamp Diameter Range	PN
1.50"	1.69" - 1.94"	30275-155
1.75"	1.94" - 2.25"	30275-175
2.00"	2.19" - 2.44"	30275-200
2.25"	2.44" - 2.75"	30275-225
2.38"	2.58" - 2.83"	30275-238
2.50"	2.63" - 2.94"	30275-250
2.75"	2.94" - 3.25"	30275-275
3.00"	3.19" - 3.50"	30275-300
3.25"	3.44" - 3.80"	30275-325
3.50"	3.69" - 4.00"	30275-350
4.00"	4.19" - 4.50"	30275-400
4.50"	4.50" - 4.81"	30275-450
5.00"	5.50" - 5.81"	30275-550

**TURBONETICS
SPEARCO BRAND INTERCOOLERS**

The Spearco brand name has been well known for unbeatable quality and performance heat exchangers for over 35 years. Whether the design is an air-to-air, liquid-to-air or liquid-to-liquid, all Spearco heat exchangers are designed and manufactured using a Bar and Plate style construction, which is superior in performance and durability to older style Tube and Fin designs. Spearco's W.A.V.E (Wide Area Vane Effectiveness) technology is the ultimate in strength and efficiency, withstanding peak pressures in excess of 200 psi. With several fin designs to choose from we are able to achieve maximum cooling effectiveness within a smaller package than traditional types of heat exchangers.

We offer a wide range of universal intercoolers with both cast and fabricated manifolds. If you cannot find what you are looking for, contact us. We will help you choose the intercooler that is right for you, or make a customized intercooler to your specifications.



**TURBONETICS
SPEARCO BRAND INTERCOOLERS**

We recommend picking a core that is rated slightly above your target horsepower to compensate for pressure drops in the air intake plumbing. Using the chart below, showing our most popular air to air intercooler cores, we produce custom intercooler assemblies with 1.75", 2.00", 2.25", 2.50", 2.75" 3.00" and 4.00" tube connections. Manifolds can be straight or tapered, and manifold orientations can be varied to fit your application. Check out www.turboneticsinc.com, or contact us with your specifications.

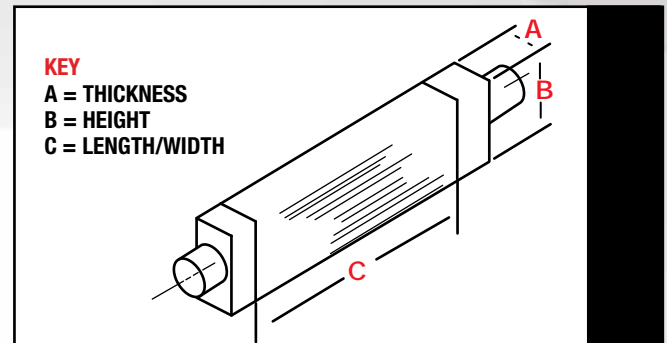

CORE PN	THICKNESS	HEIGHT	LENGTH	FLOW RATE IN CUBIC FEET/MIN	HP RATING
2-195	3.50"	9.40"	8.375"	500	350
2-110	3.50"	9.24"	6.00"	540	380
2-113	3.50"	6.80"	11.75"	320	235
2-172	3.50"	10.40"	10.50"	575	405
2-161	3.50"	7.90"	12.88"	700	490
2-120	3.50"	7.90"	24.00"	740	520
2-203	3.50"	6.52"	24.00"	740	520
2-178	3.50"	7.80"	20.00"	760	530
2-180	3.50"	13.00"	17.25"	760	530
2-127	6.00"	5.875"	22.00"	855	600
2-216	3.50"	10.50"	28.00"	860	600
2-179	4.50"	19.70"	20.75"	1000	700
2-174	4.50"	16.40"	8.75"	1050	735
2-177	4.50"	18.50"	6.50"	1080	760
2-102	3.00"	17.00"	36.00"	1400	980
2-125	3.00"	21.20"	33.00"	1400	980
2-205	3.50"	13.04"	24.00"	1400	980
70062	5.10"	12.72"	27.80"	1820	1400



Turbonetics

A Wabtec company



AIR TO AIR INTERCOOLER CORES

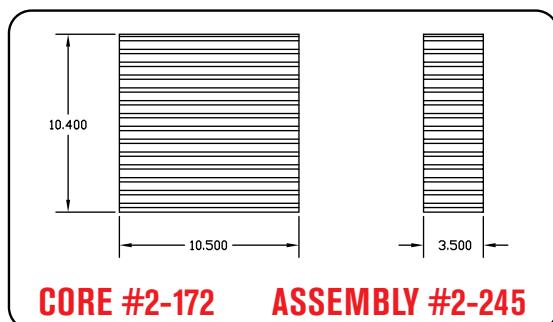
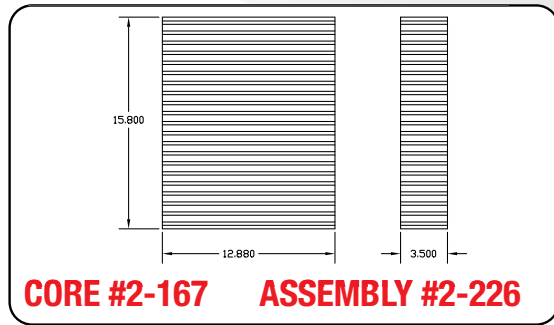
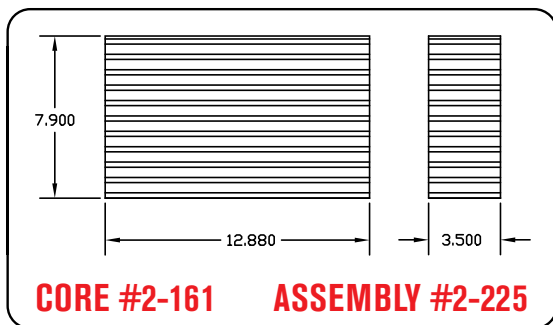
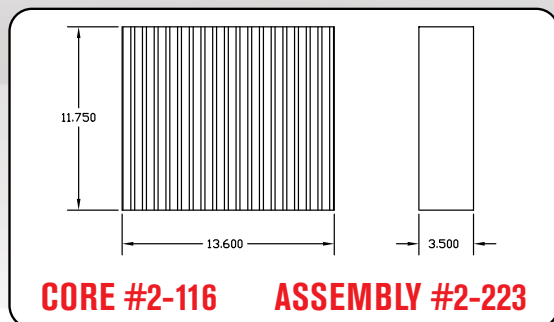
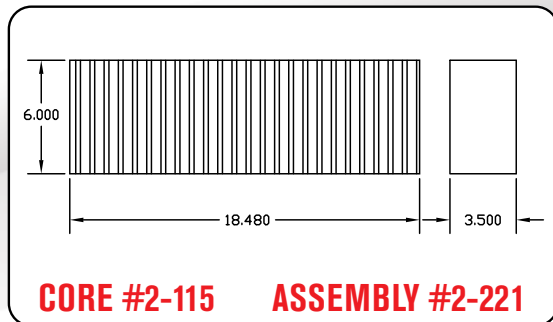
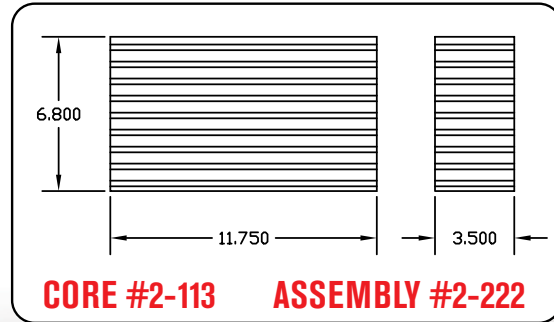
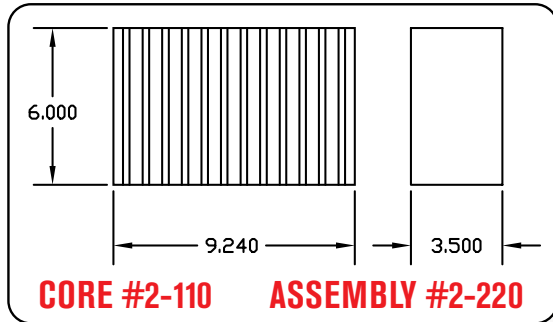

Visit www.turboneticsinc.com
for all Intercooler Core Dimensions
and full size drawings.





AIR TO AIR INTERCOOLER CORES

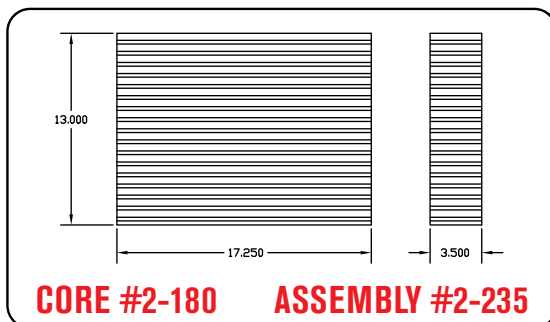
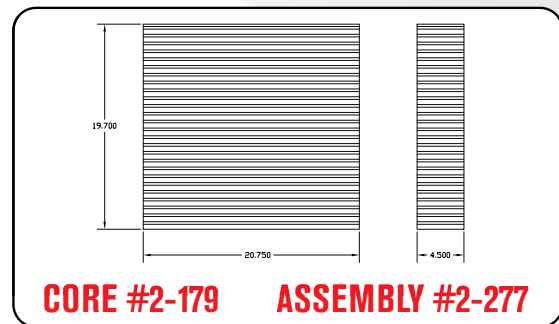
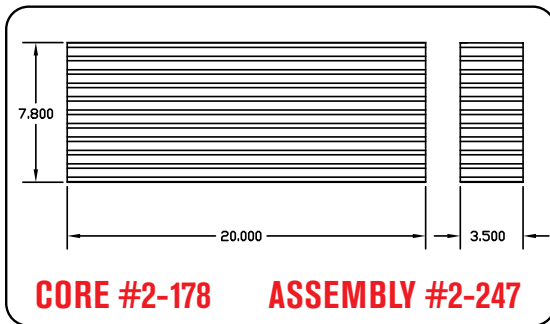
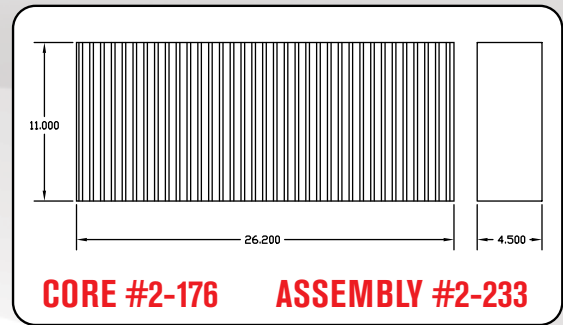
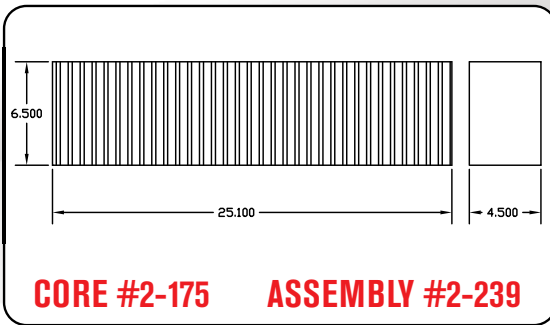
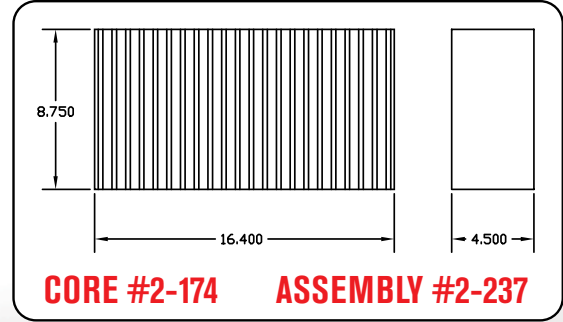
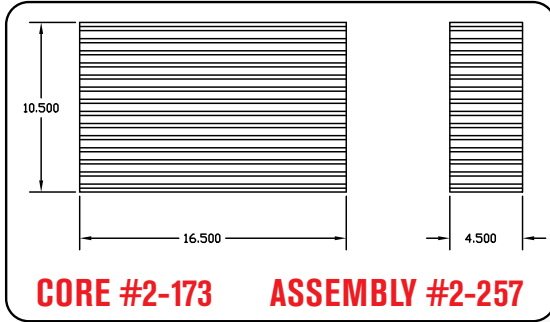

Visit www.turboneticsinc.com
for all Intercooler Core Dimensions
and full size drawings.





Turbonetics

A Wabtec company



AIR TO AIR INTERCOOLER CORES

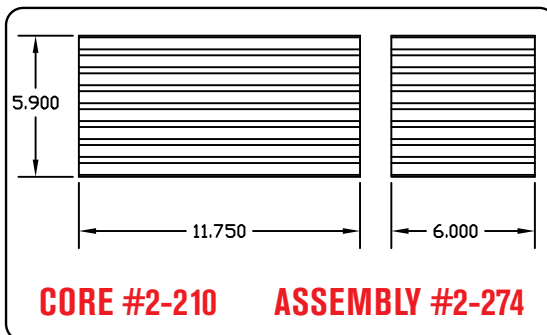
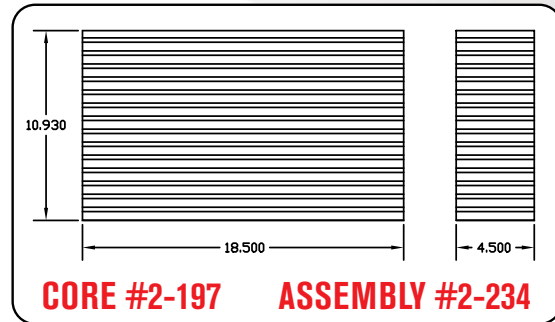
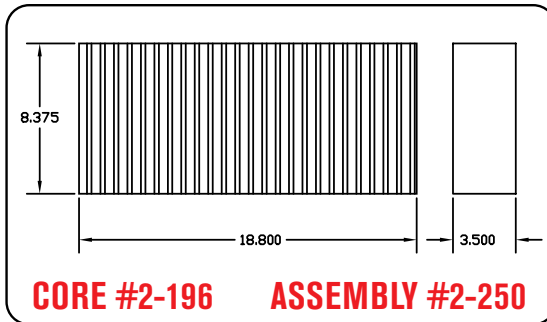
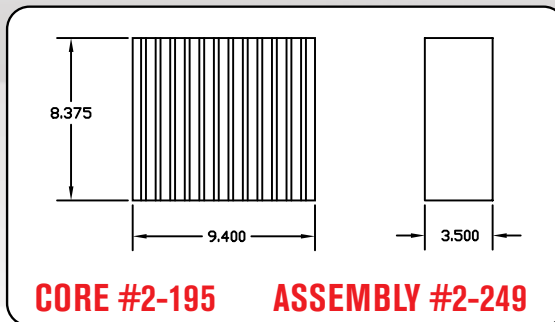
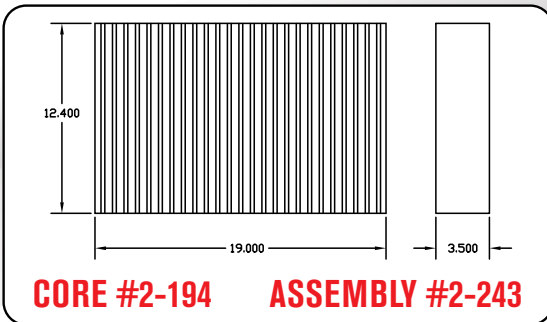
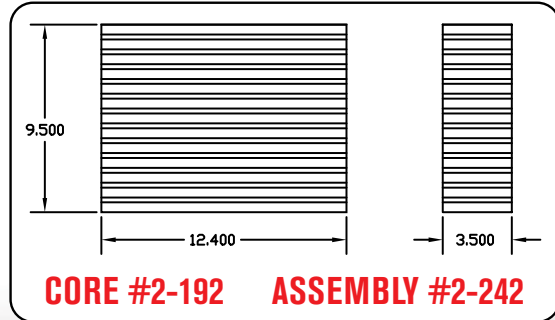
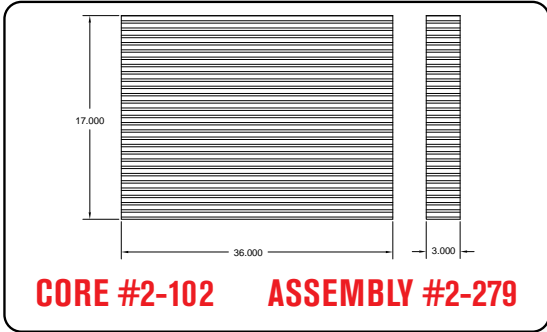

Visit www.turboneticsinc.com
for all Intercooler Core Dimensions
and full size drawings.





AIR TO AIR INTERCOOLER CORES

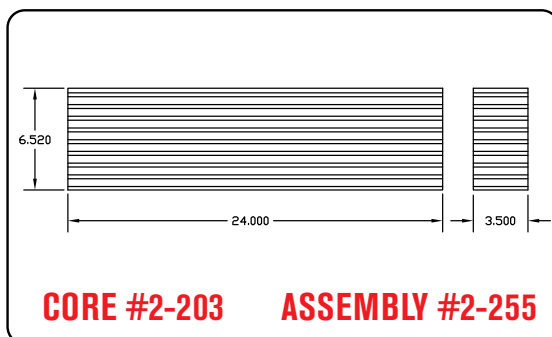
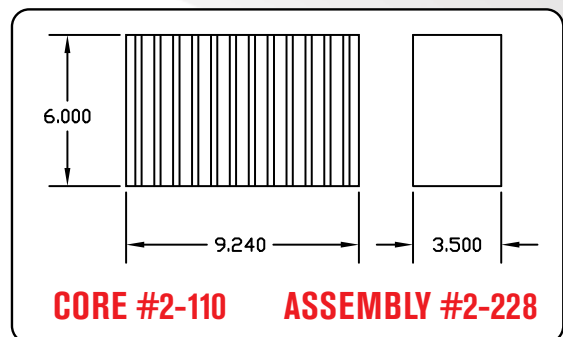
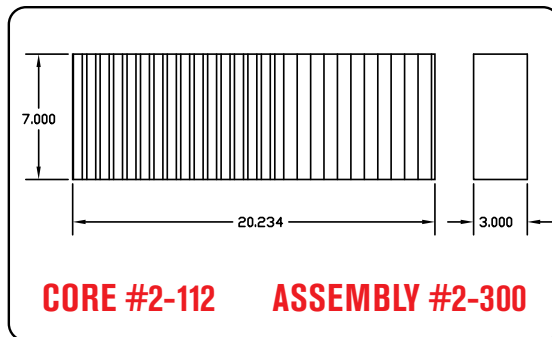
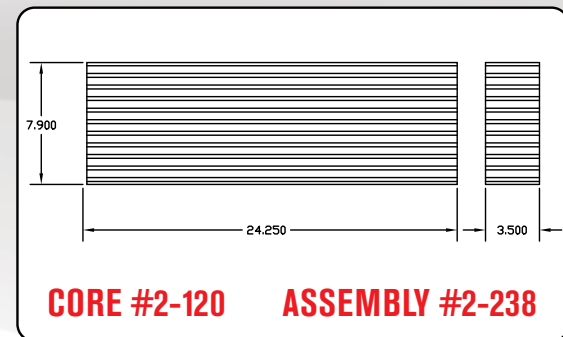
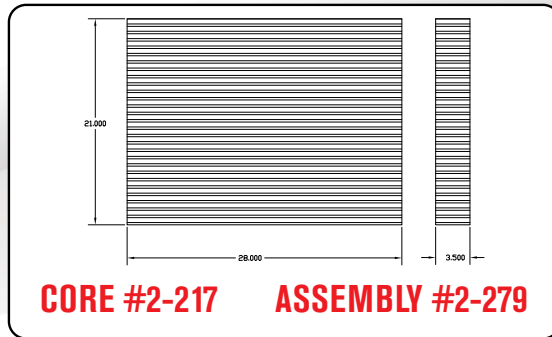
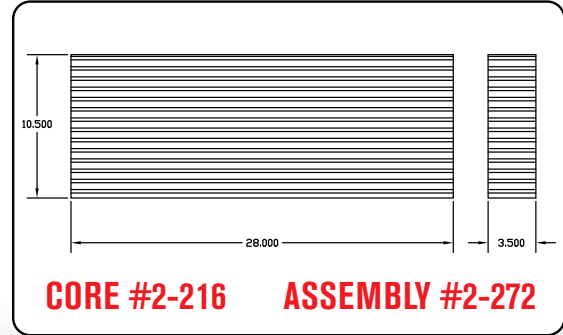
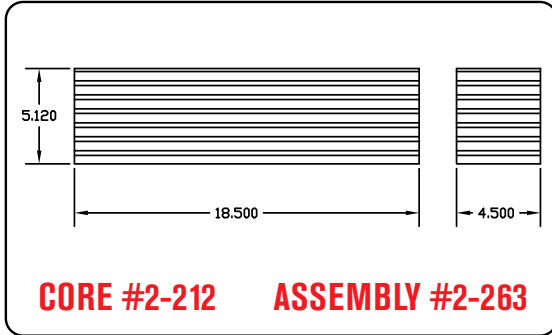

Visit www.turboneticsinc.com
for all Intercooler Core Dimensions
and full size drawings.



Turbonetics

A Wabtec company



AIR TO AIR INTERCOOLER CORES

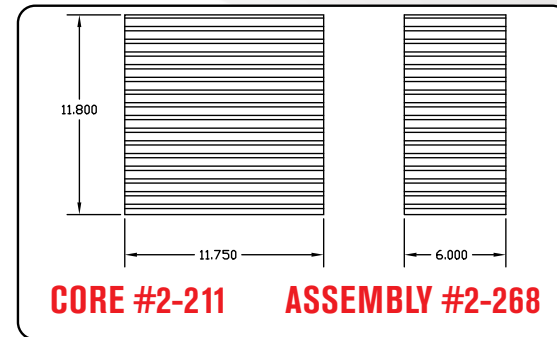
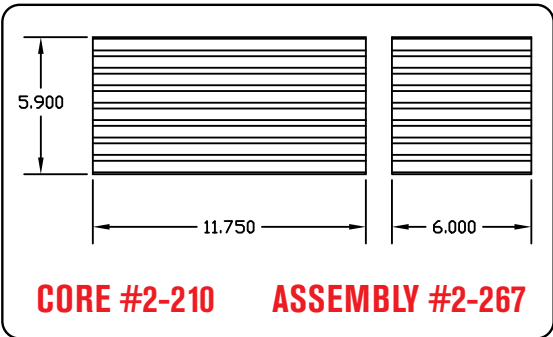
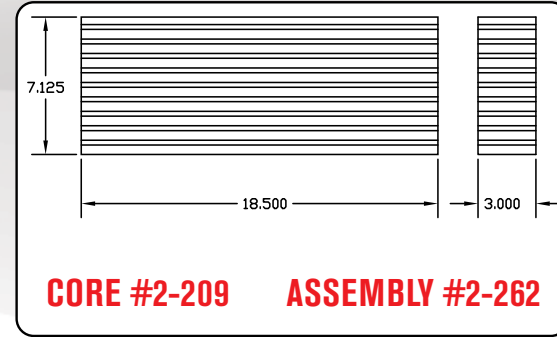
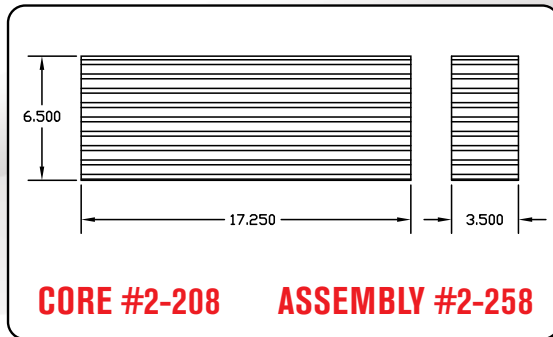
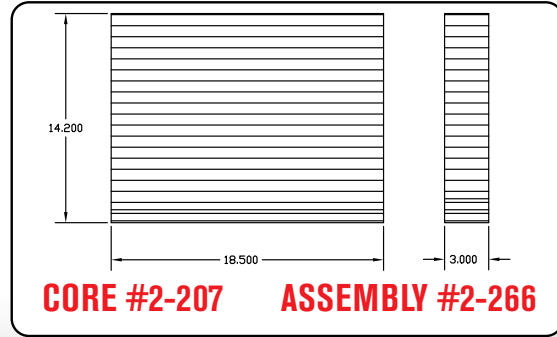
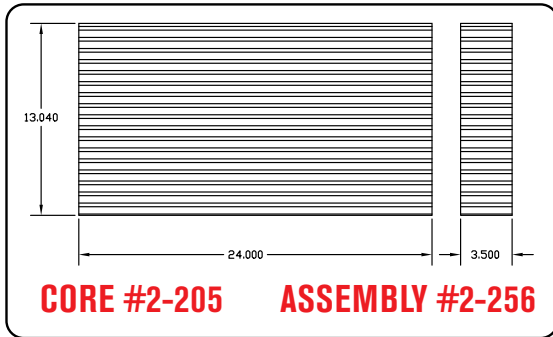

Visit www.turboneticsinc.com
for all Intercooler Core Dimensions
and full size drawings.





UNIVERSAL SPEARCO AIR TO AIR INTERCOOLERS

While the sheer amount of Turbonetics air to air intercooler versions can be overwhelming, below you can find a quick selection of our most popular complete intercoolers, in stock and ready to ship. For more core and manifold options, go to www.turboneticsinc.com or contact us.



PN 5-364



PN 2-221A-3C



PN 2-379



PN 5-377



PN 5-374



PN 5-383

HP Rating	Core Thickness	Core Height	Core Width	Hose Connection	PN
450	3.50"	7.90"	20.00"	2.50" OD	5-377
450	3.50"	7.90"	20.00"	2.50" OD	5-374
500	3.50"	7.90"	28.00"	2.50" OD	2-379
550	3.50"	7.90"	24.00"	3.00" OD	5-383
650	3.50"	10.50"	28.00"	3.00" OD	5-364
760	3.50"	9.00"	18.48"	2.50" OD	2-221A-3C





LIQUID TO AIR INTERCOOLERS



Spearco liquid to air intercoolers are best suited for racing and high boost applications, or where the engine setup does not allow for a conventional air to air unit. While installation is more involved than an air to air intercooler, liquid to air intercoolers offer superior cooling efficiency. Remarkable increases in air density and power are the result. Turbonetics offers five standard core sizes that can be combined to create customized units.



LIQUID TO AIR INTERCOOLERS					
CORE PN	THICKNESS	HEIGHT	LENGTH	FLOW RATE IN CUBIC FT/MIN	HP RATING
2-213	3.00"	4.25"	8.63"	575	405
2-206	2.25"	4.65"	7.00"	575	405
2-171	4.50"	4.50"	10.125"	570	400
2-170	4.50"	9.00"	10.125"	1000	700
2-202	6.00"	13.51"	12"	1800	1260



LIQUID TO AIR INTERCOOLER



PART NO. 2-252

Effective on engines up to 2.6L (160 CID) or 450 CFM. Available in configurations A or B.

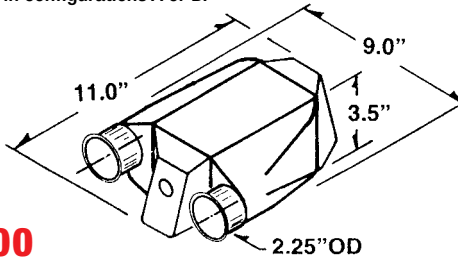

300
HORSEPOWER

PART NO. 2-270

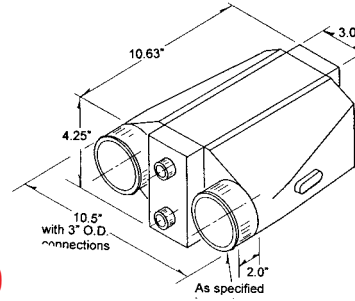

400
HORSEPOWER

PART NO. 2-265

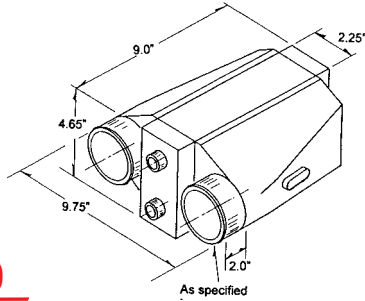

400
HORSEPOWER

PART NO. 2-231

Effective on engines up to 4.2L (260 CID) or 700 CFM. Available in configurations A or B shown below. Air manifold outlet 3" OD.

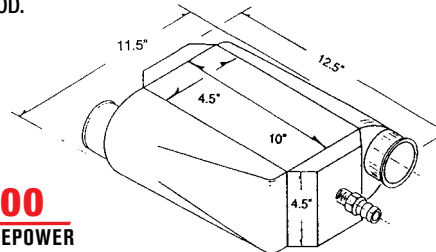

400
HORSEPOWER

PART NO. 2-278

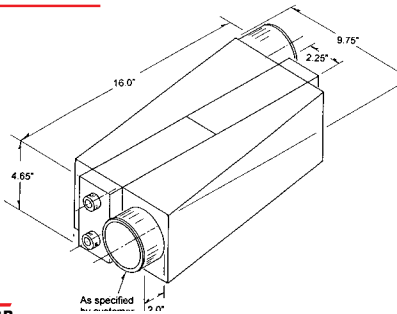

700
HORSEPOWER

PART NO. 2-269

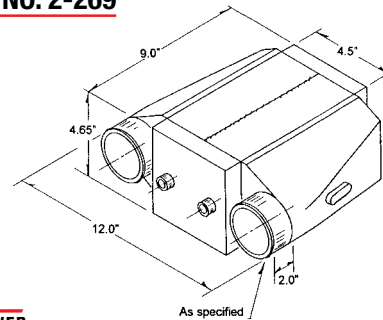

600
HORSEPOWER

PART NO. 2-271

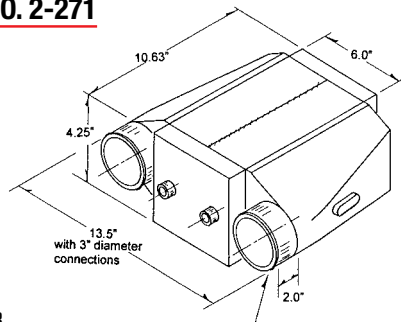

600
HORSEPOWER

PART NO. 2-279

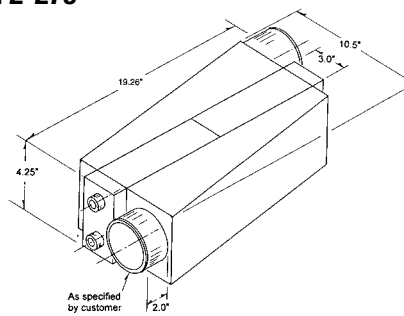

800
HORSEPOWER





LIQUID TO AIR INTERCOOLER



PART NO. 2-230

Effective on engines up to 7.4L (454 CID) or 1500 CFM. Available in configurations A, B, or C shown below. Air manifold outlet 3" OD. Core only:

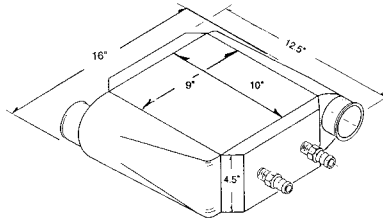

700
HORSEPOWER

PART NO. 2-254

For high horsepower racing engines up to 2500hp. Available as shown or it can be fabricated to suit your dual supercharger or turbocharger applications.

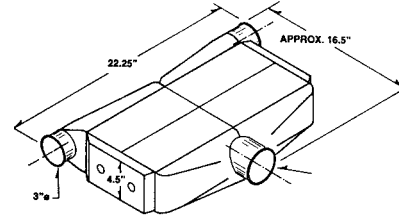

1400
HORSEPOWER

PART NO. 2-276

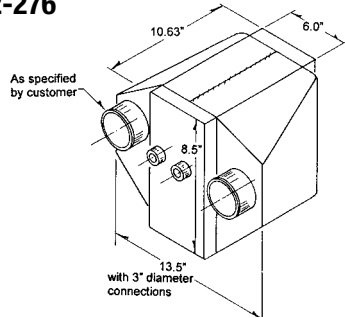

900
HORSEPOWER

PART NO. 2-259

For high horsepower racing engines up to 2500hp. Available as shown or it can be fabricated to suit your dual supercharger or turbocharger applications.

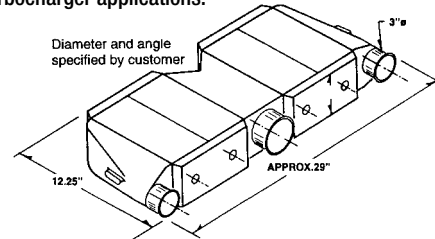

HORSEPOWER

PART NO. 2-275

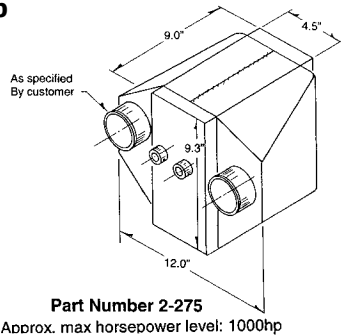

900
HORSEPOWER

Part Number 2-275
Approx. max horsepower level: 1000hp

PART NO. 2-261

For high horsepower racing engines up to 2500hp. Available as shown or it can be fabricated to suit.

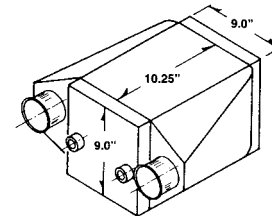

1500
HORSEPOWER

Diameter of tubes specified by customer

PART NO. 2-260

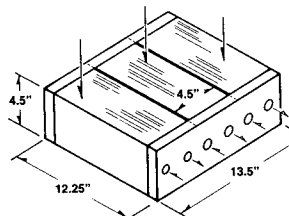

1200
HORSEPOWER

This configuration is arranged so it can be mounted on top of the intake manifold on high performance V-8 racing engines with centrifugal superchargers, custom fabricated with or without mounting flanges in 2, 3, or 4 core arrangement. This set-up gives excellent results using circulated ice water with extremely low pressure drop.

PART NO. 2-280

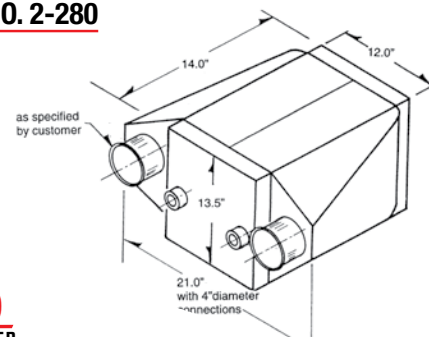

2500
HORSEPOWER





MITSUBISHI EVOLUTION X INTERCOOLER KIT

This direct bolt-on high performance intercooler upgrade features the same W.A.V.E. Technology as used in all the other high horsepower race cars. This intercooler is also the largest intercooler you can fit without any modification or cutting to the vehicle. All factory mounting brackets are retained. Computer modeled end tank design, center air inlet and outlets provide maximum boost pressure distribution, increasing cooling efficiency and dramatically reducing pressure drop. The W.A.V.E. Technology core is capable of dropping temps by as much as 220° F. Kit includes all heavy duty T-bolt clamps and silicone hose needed for installation. Approximate install time 1-2 hours.



PN 11647

*Core measures 3.5" Thick x 11.74" Tall x 20.00" Wide
**Measurement does not include end tanks





Turbonetics

A Wabtec company



SUBARU WRX/ STI INTERCOOLER KIT



Spearco's WRX intercooler kits feature the largest air-to-air, top-mount intercooler in the market. Utilizing the factory mounting points, the massive 4.5 in. thick unit bolts on easily without any modifications to the vehicle. Factory turbo piping and blow-off valves can be bolted on easily with standard hand tools. The massive 1,000 cfm intercooler offers a very low pressure drop and extremely low charge temperatures. Dyno results have shown performance improvements of up to 15 hp when compared to the stock intercooler. The kits come complete with clamps and silicone hose. Boost pressure can now be increased without the horsepower-robbing effects of the extreme charge temperatures normally associated with compressed intake air.



Subaru	WRX	NON-STI	2001-2007	2-450
Subaru	WRX	STI	2004-2007	70071



SUBARU WRX/ Non-STI INTERCOOLER KIT



Spearco's WRX intercooler kit for 2008 NON-STI models features the largest air-to-air top-mount intercooler on the market. Utilizing the factory mounting points, the massive 3.5"-thick unit bolts on with minor modifications to the vehicle. Includes aluminum hood splitter, all mounting hardware, clamps and silicone hoses. Approximate install time of 1-2 hours.

*Core measures 3.5" Thick x 7.80" Tall x 20.00" Wide
**NON-STi models ONLY



PN 11651



2010-2013 Camaro SS LS3 / L99 V8 Turbo System

STOCK RWHP 364 HP
TURBOCHARGED HP: 511 RWHP @ 6.8 PSI OF BOOST

INSTALLATION
MAJOR COMPONENTS:

- Installs in one day
- No modifications to chassis required - no cutting or splicing of electrical components

- 15192** - Camaro V-8 LS3 Tuner / Stage 2 Turbo System
- 15194** - Camaro V-8 LS3 Tuner / Stage 2 Turbo System
- 15193** - Camaro V8 Complete Turbo System L99 Automatic Transmission 50 State Legal EOD-99-8
- 15195** - Camaro V8 Tuner Turbo System L99 Automatic Transmission Turner / Stage 2 Kit

Tuner / Stage 2 system is for off road use only. It's the same as our complete system minus, spark plugs, fuel pump controller, tuner, injectors and air filter. The kit does come with larger wastegates and turbo.

SYSTEM INCLUDES:
MAJOR COMPONENTS:

- Turbonetics T76 Ceramic Ball Bearing Turbocharger
- Massive Spearco Front Mount Intercooler with 4.5x26x11" core
- Two Turbonetics Evolution 35mm wastegates
- Turbosmart by-pass valve
- T304 stainless steel TIG welded exhaust plumbing
- Aluminum intercooler and air intake plumbing
- 8x630cc/min fuel injectors
- 8x NGK TR6 spark plugs
- Diablo handheld programmer with CARB legal Tune
- Coolant/window wash fluid reservoirs
- Hardware kit (fasteners, gaskets, clamps, instructions, EO label, etc.)

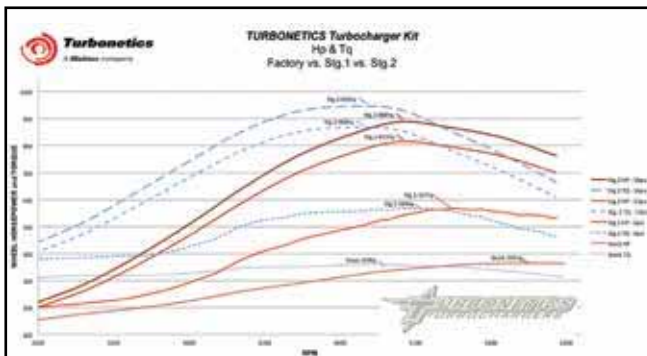



Turbonetics

A Wabtec company



GM DURAMAX DIESEL UPGRADES



Upgrading a stock Chevrolet or GMC 6.6l Duramax is easy with Spearco Intercooler upgrades and a pedestal that allows installation of any T4 flanged turbocharger.

THE PEDESTAL KIT FEATURES:

- Investment cast stainless steel pedestal
- T4 flange for a wide selection of turbochargers
- Integrated wastegate flange, including block-off flange, gasket and 2 bolts
- Drop-in OE quality fit - no riser plates needed



PN 2-486

The Spearco intercooler upgrades are available for all engine versions. No modifications to the engine bay required, the intercoolers drop right into the stock location. The intercooler upgrade are essential when replacing the stock turbo with a larger turbocharger to deliver cool air to the Duramax engine.

DURAMAX DIESEL UPGRADES			
VEHICLE	YEAR	PRODUCT DESCRIPTION	PN
GM Duramax 6.6l LB7	2001 - 2004	Intercooler upgrade kit, 150°F average intake temp. drop < 1psi pressure drop, direct bolt on	2-486
GM Duramax 6.6l LBZ	2006 - 2007	Intercooler upgrade kit, 150°F average intake temp. drop < 1psi pressure drop, direct bolt on	2-487
GM Duramax 6.6l LLY	2004 - 2005	Intercooler upgrade kit, 150°F average intake temp. drop < 1psi pressure drop, direct bolt on"	2-486
GM Duramax 6.6l LMM	2007 - 2010	Intercooler upgrade kit, 150°F average intake temp. drop < 1psi pressure drop, direct bolt on	2-487





Turbonetics

A **Wabtec** company



FORD POWERSTROKE DIESEL UPGRADES

The Ford family of engines see fantastic gains from bolting on these turbo and intercooler upgrades. Turbonetics offers both intercooler and turbo upgrades the 7.3 and 6.0, and an intercooler upgrade for the 6.4. Perfectly designed for towing, the Stage 1 turbo and intercooler bring both the 6.0L and 7.3L to life. Our high powered Stage 2 and Stage 3 are available for extreme upgrades.

You can now fit a massive 24x23.5x3.5" (core size) intercooler in either the 6.0 and the 7.3L Fords. Both are available in complete bolt on kits and come with cast end tanks for added strength.



6.0L FORD TURBO UPGRADE



6.0 & 7.3 Ford Intercooler

POWERSTROKE DIESEL UPGRADES			
VEHICLE	YEAR	PRODUCT DESCRIPTION	PN
Ford 6.0L Powerstroke Diesel	2003 - 2007	Turbo upgrade pedestal only, stainless steel	21653
Ford 6.0L Powerstroke Diesel	2003 - 2007	Turbo upgrade pedestal kit includes all hardware to install any T4 flange turbocharger and connect to stock V-band exhaust.	11313
Ford 6.0L Powerstroke Diesel	2003 - 2007	Turbo upgrade kit Stage I Pedestal, hardware and ball bearing turbo (11470-BB T6168, 0.58 A/R, 3.5" V-band) Capable of 500HP, 700 ft/lb, 40psi boost. Programmer/tune not included.	15180
Ford 6.0L Powerstroke Diesel	2003-2007	Intercooler upgrade kit, 150°F average intake temp. drop < 1psi pressure drop, direct bolt on	70057
Ford 6.4L Powerstroke Diesel	2007 and up	Intercooler upgrade kit, 150°F average intake temp. drop < 1psi pressure drop, direct bolt on	2-488
Ford 7.3L Powerstroke	1999.5 - 2003	Intercooler upgrade kit, 150°F average intake temp. drop < 1psi pressure drop, direct bolt on	70058





Turbonetics

A Wabtec company



DODGE CUMMINS DIESEL UPGRADES



Get the maximum out of your Dodge Cummins 5.9l with a selection of carefully designed intercooler and turbo upgrades. With several kits available for towing, street performance or extreme power, you can choose your perfect fit. All intercooler upgrades bolt-on directly to the factory engine.

Kits available for towing, street performance or extreme power.

POWERSTROKE DIESEL UPGRADES

VEHICLE	YEAR	PRODUCT DESCRIPTION	PN
Dodge Cummins 12V Diesel	1994 - 1998	Intercooler upgrade kit, 150°F average intake temp. drop < 1psi pressure drop, direct bolt on	2-479
Dodge Cummins 24V Diesel	1998.5 - 2002	Intercooler upgrade kit, 150°F average intake temp. drop < 1psi pressure drop, direct bolt on	2-479
Dodge Cummins 24V CRD	2003 - 2006	Intercooler upgrade kit, 150°F average intake temp. drop < 1psi pressure drop, direct bolt on	2-477
Dodge Cummins 24V CRD	2007	Intercooler upgrade kit, 150°F average intake temp. drop < 1psi pressure drop, direct bolt on	2-477



Turbonetics

A **Wabtec** company

TERMS & CONDITIONS/RMA INSTRUCTIONS

TERMS AND CONDITIONS

The following Terms and Conditions are effective November 1, 2006 and are subject to change without notice.

PAYMENT METHOD

Visa, MasterCard, American Express, cashier's check, and money order are accepted. Company checks are accepted only upon approval.

HEAT EXCHANGER ORDERS

All heat exchanger products are subject to customer-approved drawings and a 50% deposit prior to acceptance of the order. No returns or exchanges on customer-approved heat exchanger products will be accepted.

SHIPPING

All shipments are Moorpark, California, USA Shipping charges include insurance for full value of the product unless prohibited by the shipping agency.

FINAL SHIPMENT HOUR

Orders received no later than 2:00PM(14:00) will be shipped that day, inventory levels permitting.

AUTOMATIC ORDER CANCELLATION

Unless told otherwise, Turbonetics will automatically cancel open orders (backorders) after 60 days from the order entry date.

CLAIMS

A claim for damage in transit must be made by the customer directly to the shipping agency as soon as the damage is discovered. Turbonetics is not liable for the condition of merchandise as handled by the shipper once the shipper has accepted delivery from Turbonetics.

RETURNED GOODS AUTHORIZATION TRACKING NUMBER

Turbonetics will only accept product returns, repair orders/upgrades, and warranty requests that have been approved and are returned with a corresponding Returned Goods Authorization (RGA) tracking number. Contact Turbonetics for approval and the RGA number. Write the RGA number clearly on the outside of the package and include it inside the package. This is very important in allowing us to properly identify and process your request. Failure to comply with this requirement will result in the delay of processing or the product being returned to you.

RETURN POLICY

Only unused and complete merchandise may be accepted for return subject to inspection and acceptance by Turbonetics. No goods will be accepted without prior return authorization from Turbonetics. Call for approval and RGA (Returned Goods Authorization) tracking number.

- No returns will be accepted without an RGA tracking number. No returns will be accepted after ninety (90) days from the original shipping date from Turbonetics unless approved. All approved returns are subject to a 15% restocking charge NO EXCEPTIONS.
- The original invoice must accompany the return.
- All customized products are non-refundable & non-returnable, as it states on the Turbonetics invoice.
- Approved returns will be issued credit only.

REPAIR ORDERS/PERFORMANCE UPGRADES

Contact a Sales and Technical Support Representative for information on turbocharger and related product repairs and performance upgrades. Available options, estimated pricing, shipment method, and RGA (Returned Goods Authorization) tracking number will be communicated at the time of the call. After receipt of the product, we will contact you with our visual inspection evaluation and final pricing. Any reman left at Turbonetics beyond 60 days will become property of Turbonetics/will be scrapped or discarded.

REFUSED SHIPMENTS

Sending a shipment back to Turbonetics does not automatically constitute the right to a refund or credit. Turbonetics may, at its discretion, require different payment means for any reshipped refused shipments. It is the customer's responsibility to make all arrangements with Turbonetics for disposition of the refused shipment. Customer is responsible for all outgoing and return shipping and handling charges regardless of disposition of refused shipment. Accounts that refuse a COD-Cashier's Check/Money Order shipment will require a new payment method prior to acceptance of future orders.

RETURNED CHECKS

Any customer checks returned to Turbonetics for insufficient funds from any institution will incur a \$25.00 USD processing charge. Any customer who submits an invalid check will be refused further shipments until such time as any outstanding debt is cleared. Customers submitting invalid checks are subject to cancellation of their buying status and/or their payment terms. Turbonetics will prosecute any fraudulent payments to the full extent of the law.

WARRANTY-"NO-FAULT/NO-HASSLE" WARRANTY PROGRAM

Turbonetics will repair or replace, at our expense, any new Turbonetics / Spearco products that fail, including products used in racing or competition applications, for a period of one year from the original date of purchase. All turbocharger and cartridge assemblies (except Midframe, Y2K and Thumper) have a factory installed inline oil filtration device. This filter device must remain in place if any warranty is to be considered under the No-Fault / No-Hassle program. Warranty is limited to Turbonetics products and does not include progressive or subsequential damage and does not cover removal or installation labor or associated parts. Remanufactured units, upgraded units, and O.E.M. replacement units are covered by a 90-day warranty or the O.E. warranty period. Warranty is non-transferable and must be processed via the original purchaser from Turbonetics. Contact Turbonetics for return approval, RGA (Returned Goods Authorization) tracking number, and shipping method PRIOR to sending the product to Turbonetics. Our Customer Service Representative will provide packaging and shipping instructions. Please include your invoice with the shipment. Turbonetics products are manufactured to strict quality standards using all the latest and highest grade materials. All turbochargers are professionally assembled and VSR tested as complete assemblies to assure proper balance, oil flow and long life with trouble free performance. Turbonetics highly recommends that the installation of mechanical or electrical parts be performed by trained professionals. Improperly installed products may lead to unsafe and unreliable conditions.



14399 PRINCETON AVE, MOORPARK, CA 93021

TEL : (805) 581- 0333/FAX:(805) 584-1913

Call the Turbonetics Customer Service Department @ (805) 581-0333. Be prepared to provide the representative with the Warranty Registration Number. The Customer Service Representative will provide you with a RGA (Returned Goods Authorization) number, packing and shipping instruction. The RGA number must be clearly marked on the outside of the box and all accompanying documentation. Information regarding the failure or damage must also accompany the components, i.e., mileage, description of defect, point of purchase, etc. Any warranty requests sent to Turbonetics without a RGA number will be refused. The Customer (MWD/WD/End-user) is responsible for all freight charges. Please allow 10-15 business days for turn-around.

Note: Turbochargers that are sent in to Turbonetics under the warranty claim and under inspection the unit is found to have zero manufacturer defects, the customer will be subject to standard repair fees and shipping charges. Actual products may vary from pictorial representations in catalog.



turboneticsinc.com



14399 PRINCETON AVE, MOORPARK, CA 93021
TEL : (805) 581- 0333/FAX:(805) 584-1913